

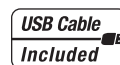

MP3/WMA/AAC CD Receiver

CDA-117

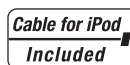

- OWNER'S MANUAL  
Please read before using this equipment.
- MODE D'EMPLOI  
Veuillez lire avant d'utiliser cet appareil.
- MANUAL DE OPERACIÓN  
Léalo antes de utilizar este equipo.

**ALPINE ELECTRONICS MARKETING, INC.**  
1-1-8 Nishi Gotanda,  
Shinagawa-ku,  
Tokyo 141-0031, Japan  
Phone 03-5496-8231

**ALPINE ELECTRONICS OF AMERICA, INC.**  
19145 Gramercy Place, Torrance,  
California 90501, U.S.A.  
Phone 1-800-ALPINE-1 (1-800-257-4631)

**ALPINE ELECTRONICS OF CANADA, INC.**  
777 Supertest Road, Toronto,  
Ontario M3J 2M9, Canada  
Phone 1-800-ALPINE-1 (1-800-257-4631)

**ALPINE ELECTRONICS OF AUSTRALIA PTY. LTD.**  
161-165 Princes Highway, Hallam  
Victoria 3803, Australia  
Phone 03-8787-1200

**ALPINE ELECTRONICS GmbH**  
Wilhelm-Wagenfeld-Str. 1-3, 80807 München, Germany  
Phone 089-32 42 640

**ALPINE ELECTRONICS OF U.K. LTD.**  
Alpine House  
Fletchamstead Highway, Coventry CV4 9TW, U.K.  
Phone 0870-33 33 763

**ALPINE ELECTRONICS FRANCE S.A.R.L.**  
(RCS PONTOISE B 338 101 280)  
98, Rue de la Belle Etoile, Z.I. Paris Nord II,  
B.P. 50016, 95945 Roissy Charles de Gaulle  
Cedex, France  
Phone 01-48638989

**ALPINE ITALIA S.p.A.**  
Viale C. Colombo 8, 20090 Trezzano  
Sul Naviglio (MI), Italy  
Phone 02-484781

**ALPINE ELECTRONICS DE ESPAÑA, S.A.**  
Portal de Gamarra 36, Pabellón, 32  
01013 Vitoria (Alava)-APDO 133, Spain  
Phone 945-283588

**ALPINE ELECTRONICS (BENELUX) GmbH**  
Leuvensesteenweg 510-B6,  
1930 Zaventem, Belgium  
Phone 02-725-13 15

EN

FR

ES



## Operating Instructions

### WARNING

WARNING .....	4
CAUTION .....	4
PRECAUTIONS .....	4

### Getting Started

Accessory List .....	7
Turning Power On and Off .....	7
Source Selection .....	7
Detaching and Attaching the Front Panel .....	7
Detaching .....	7
Attaching .....	7
Initial System Start-Up .....	8
Adjusting Volume .....	8
Lowering Volume Quickly .....	8
Setting the Time and Calendar .....	8

### Radio

Listening to Radio .....	9
Presetting Stations Manually .....	9
Presetting Stations Automatically .....	9
Tuning to Preset Stations .....	9
Frequency Search Function .....	9
Receiving a Multicast Station (HD Radio™ mode only) .....	10

### RBDS

Setting the Time to automatically Adjust .....	10
Receiving Traffic Information .....	11
PTY (Program Type) Tuning .....	11
Receiving Traffic Information While Playing CD or Radio .....	11
Using iTunes tagging .....	11
Displaying Radio Text .....	12

### CD/MP3/WMA/AAC

Playback .....	12
Repeat Play .....	13
M.I.X. (Random Play) .....	13
Searching for CD Text .....	13
Folder/File Name Search (Concerning MP3/WMA/AAC) .....	13
Folder Name Search mode .....	13
File Name Search mode .....	13
Quick Search .....	14

Search Position Memory .....	14
About MP3/WMA/AAC .....	14
Terminology .....	15

### Sound Setting

Adjusting Subwoofer Level/Balance (Between Left and Right)/Fader (Between Front and Rear)/Black Out/Defeat .....	15
Sound Setting .....	16
Adjusting the High Pass Filter .....	16
Turning Subwoofer ON/OFF .....	16
Setting the Subwoofer System .....	16
Setting the Subwoofer Phase .....	16
Setting the Subwoofer Channel (SUBW. Channel) .....	16
Turning Media Xpander ON/OFF .....	16
Setting the MX Level .....	16
Setting EQ mode .....	17
Setting the Time Correction Unit (TCR Parameter) .....	17
Sound Field Adjustment .....	17
Adjusting the Parametric Equalizer Curve .....	17
Adjusting the Graphic Equalizer Curve .....	17
Adjusting the Time Correction .....	17
Storing the Sound Field Adjustment Settings .....	18
Recalling the Stored Sound Field Adjustment Settings .....	18

### Other Functions

Displaying the Text .....	18
About the indication display .....	19
About "Text" .....	20
Displaying Time .....	20

### SETUP

Setting .....	20
BLUETOOTH Setting .....	21
Setting the BLUETOOTH Connection .....	21
General Setting .....	21
Birthday Opening Message Setting (Birthday Set) .....	21
Setting the Clock Display (Clock Mode) .....	21
Setting of Calendar Display Pattern Switching (Calendar) .....	21
Playing MP3/WMA/AAC Data (Play Mode) .....	21
Sound (Beep) Guide Function .....	21
Turning Mute Mode On/Off (INT Mute) .....	22
Setting the AUX+ Setup Mode .....	22
Setting the AUX+ Level (AUX IN GAIN) .....	22
Setting the External Digital Input .....	22
Setting the AUX Mode (V-Link) .....	22
Changer Name Setting .....	22
Connecting to an External Amplifier .....	22

- Setting the Language Font .....23
- Demonstration .....23
- Display Setting ..... 23
- Dimmer Control .....23
- Dimmer Level Setting .....23
- Scroll Type Setting .....23
- Scroll Setting (Text Scroll) .....23
- Switching the Character Font .....23
- Switching the Animation Display Type (BGV Select) .....23
- Opening Message ON/OFF Setting .....24
- Tuner Setting ..... 24
- Setting the TUNER (FM) tone quality .....24
- SIRIUS Radio Setting (Only when a SIRIUS Receiver Box is connected)..... 24
- Unlock the Locked Channels.....24
- Clearing the Setting of Skipped Channels .....24
- Setting the Favorite Sports Team announcement.....24
- Setting the Sirius Seek (S-Seek) Alert.....24
- HD Radio Reception (only when HD Radio Tuner module is connected) ..... 25
- HD Radio Station Call Setting .....25
- Digital Seek ON/OFF Setting .....25

## SAT Radio Receiver (optional)

- Receiving Channels with the SAT Radio Receiver (optional)..... 26
- Checking the SAT Radio ID Number..... 26
- Storing Channel Presets ..... 26
- Receiving Stored Channels..... 27
- Storing the desired Sports Team (SIRIUS only) ..... 27
- Storing while receiving a game broadcast ..... 27
- Storing the desired Artist/Song (SIRIUS only) ..... 27
- Activating the stored Alert (SIRIUS only) ..... 27
- Search Function ..... 28
- Category Search mode ..... 28
- Channel Search mode ..... 28
- Quick Search Function ..... 28
- Receiving Weather or Traffic Information from SAT Radio ..... 28
- Instant Replay Function (SIRIUS only)..... 28
- Changing the Display ..... 29
- Setting the Auxiliary Data Field Display (XM only) ..... 29

## USB Memory/Portable audio player (optional)

- Connecting the USB Memory (optional).....30
- Using the USB Memory/Portable audio player Banking Function.....30
- Playback .....30
- Repeat Play .....30
- M.I.X. (Random Play) .....31
- Searching for a desired Song .....31
- Searching by artist name .....31
- Select Playlist/Artist/Album/Genre/Composer/Folder.....31
- Alphabet Skip Function.....32
- Quick Search.....32
- Search Position Memory .....32

## iPhone/iPod (optional)

- Connecting an iPhone/iPod.....32
- Playback .....33
- Searching for a desired Song .....33
- Searching by artist name .....33
- Quick Search.....33
- Direct Search Function .....34
- Select Playlist/Artist/Album/Genre/Composer/Episode .....34
- Alphabet Skip Function.....34
- Search Position Memory .....34
- Random Play Shuffle (M.I.X.) .....34
- Repeat Play .....34
- Displaying the Text.....35

## IMPRINT Operation (optional)

- Changing MultEQ mode .....35
- Adjusting Subwoofer Level/Bass Level/Treble Level/Fader (Between Front and Rear)/Balance (Between Left and Right)/Black Out in MultEQ mode .....36
- Adjusting Sound Setting in Manual Mode .....36
- Turning Subwoofer ON/OFF .....36
- Setting the Subwoofer System .....36
- Setting the Subwoofer Phase.....37
- Setting the Subwoofer Channel (SUBW. Channel) .....37
- Equalizer Presets (Factory's EQ) .....37
- Setting the Response Slope for the High Range Speaker (TW Setup) .....37
- Setting the Filter type .....37
- Turning Media Xpander ON/OFF .....37

Setting the MX Level.....	37
Setting EQ mode.....	37
Setting the Time Correction Unit (TCR Parameter).....	38
Sound Field Adjustment.....	38
Adjusting the Parametric Equalizer Curve .....	38
Adjusting the Graphic Equalizer Curve .....	38
Adjusting the Time Correction.....	38
Adjusting the Crossover Settings .....	38
Storing the Sound Field Adjustment Settings.....	39
Recalling the Stored Sound Field Adjustment Settings .....	39
About Time Correction .....	39
Example 1: Front Left Seat .....	40
Example 2: All Seats .....	40
About the Crossover .....	41

## Changer (optional)

Controlling CD Changer (optional).....	42
Playing MP3 Files with the CD Changer (optional).....	43
Multi-Changer Selection (optional).....	43

## Remote Control

Controls on Remote Control .....	43
Operating the Audio Processor.....	44
Battery Replacement .....	44
Controllable With Remote Control .....	44
Connectable to Remote Control Interface Box.....	44

## Information

In Case of Difficulty.....	45
Basic .....	45
Radio.....	45
CD .....	45
MP3/WMA/AAC .....	45
Audio.....	45
iPod .....	45
Indication for CD Player.....	45
Indication for CD Changer.....	46
Indication for SAT Receiver Mode .....	46
Indication for USB Memory/Portable audio player.....	47
Indication for iPhone/iPod Mode.....	47
Specifications .....	48

## Installation and Connections

<b>Warning .....</b>	<b>49</b>
<b>Caution .....</b>	<b>49</b>
<b>Precautions .....</b>	<b>49</b>
Installation .....	50
Removal .....	50
iPhone/iPod Connection (sold separately).....	51
Remove the iPhone/iPod.....	51
USB Memory Connection (sold separately).....	51
Connect USB Memory .....	51
Remove USB Memory .....	51
Connections .....	52

## LIMITED WARRANTY

# Operating Instructions

## WARNING



### WARNING

This symbol means important instructions. Failure to heed them can result in serious injury or death.

#### DO NOT OPERATE ANY FUNCTION THAT TAKES YOUR ATTENTION AWAY FROM SAFELY DRIVING YOUR VEHICLE.

Any function that requires your prolonged attention should only be performed after coming to a complete stop. Always stop the vehicle in a safe location before performing these functions. Failure to do so may result in an accident.

#### KEEP THE VOLUME AT A LEVEL WHERE YOU CAN STILL HEAR OUTSIDE NOISES WHILE DRIVING.

Excessive volume levels that obscure sounds such as emergency vehicle sirens or road warning signals (train crossings, etc.) can be dangerous and may result in an accident. LISTENING AT LOUD VOLUME LEVELS IN A CAR MAY ALSO CAUSE HEARING DAMAGE.

#### DO NOT DISASSEMBLE OR ALTER.

Doing so may result in an accident, fire or electric shock.

#### USE ONLY IN CARS WITH A 12 VOLT NEGATIVE GROUND.

(Check with your dealer if you are not sure.) Failure to do so may result in fire, etc.

#### KEEP SMALL OBJECTS SUCH AS BATTERIES OUT OF THE REACH OF CHILDREN.

Swallowing them may result in serious injury. If swallowed, consult a physician immediately.

#### USE THE CORRECT AMPERE RATING WHEN REPLACING FUSES.

Failure to do so may result in fire or electric shock.

#### DO NOT BLOCK VENTS OR RADIATOR PANELS.

Doing so may cause heat to build up inside and may result in fire.

#### USE THIS PRODUCT FOR MOBILE 12V APPLICATIONS.

Use for other than its designed application may result in fire, electric shock or other injury.

#### DO NOT PLACE HANDS, FINGERS OR FOREIGN OBJECTS IN INSERTION SLOTS OR GAPS.

Doing so may result in personal injury or damage to the product.



### CAUTION

This symbol means important instructions. Failure to heed them can result in injury or material property damage.

#### HALT USE IMMEDIATELY IF A PROBLEM APPEARS.

Failure to do so may cause personal injury or damage to the product. Return it to your authorized Alpine dealer or the nearest Alpine Service Center for repairing.

#### DO NOT MIX NEW BATTERIES WITH OLD BATTERIES. INSERT WITH THE CORRECT BATTERY POLARITY.

When inserting the batteries, be sure to observe proper polarity (+ and -) as instructed. Rupture or chemical leakage from the battery may cause fire or personal injury.



### PRECAUTIONS

#### Product Cleaning

Use a soft dry cloth for periodic cleaning of the product. For more severe stains, please dampen the cloth with water only. Anything else has the chance of dissolving the paint or damaging the plastic.

#### Temperature

Be sure the temperature inside the vehicle is between +60°C (+140°F) and -10°C (+14°F) before turning your unit on.

#### Moisture Condensation

You may notice the CD playback sound wavering due to condensation. If this happens, remove the disc from the player and wait about an hour for the moisture to evaporate.

#### Damaged Disc

Do not attempt to play cracked, warped, or damaged discs. Playing a bad disc could severely damage the playback mechanism.

#### Maintenance

If you have problems, do not attempt to repair the unit yourself. Return it to your Alpine dealer or the nearest Alpine Service Station for servicing.

#### Never Attempt the Following

Do not grip or pull out the disc while it is being pulled back into the player by the automatic reloading mechanism. Do not attempt to insert a disc into the unit when the unit power is off.

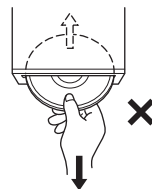

#### Inserting Discs

Your player accepts only one disc at a time for playback. Do not attempt to load more than one disc. Make sure the label side is facing up when you insert the disc. "Error" will be displayed on your player if you insert a disc incorrectly. If "Error" continues to be displayed even though the

disc has been inserted correctly, push the RESET switch with a pointed object such as a ballpoint pen.

Playing a disc while driving on a very bumpy road may result in skips, but this will not scratch the disc or damage the player.

### New Discs

To prevent the CD from jamming, "Error" is displayed if discs with irregular surfaces are inserted or if discs are inserted incorrectly. When a new disc is ejected immediately after initial loading, use your finger to feel around the inside of the center hole and outside edge of the disc. If you feel any small bumps or irregularities, this could inhibit proper loading of the disc. To remove the bumps, rub the inside edge of the hole and outside edge of the disc with a ballpoint pen or other such instrument, then insert the disc again.

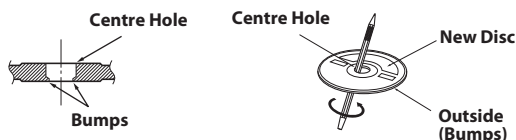

### Irregular Shaped Discs

Be sure to use round shape discs only for this unit and never use any special shape discs.

Use of special shape discs may cause damage to the mechanism.



### Installation Location

Make sure this unit will not be installed in a location subjected to:

- Direct sun and heat
- High humidity and water
- Excessive dust
- Excessive vibrations

### Correct Handling

Do not drop the disc while handling. Hold the disc so you will not leave fingerprints on the surface. Do not affix tape, paper, or gummed labels to the disc. Do not write on the disc.

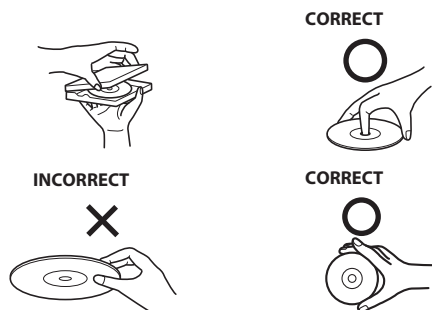

### Disc Cleaning

Fingerprints, dust, or soil on the surface of the disc could cause the CD player to skip. For routine cleaning, wipe the playing surface with a clean, soft cloth from the center of the disc to the outer edge.

If the surface is heavily soiled, dampen a clean, soft cloth in a solution of mild neutral detergent before cleaning the disc.



### Disc Accessories

There are various accessories available on the market for protecting the disc surface and improving sound quality. However, most of them will influence the thickness and/or diameter of the disc. Using such accessories can cause the disc to be out of standard specifications and may create operational problems. We recommend not using these accessories on discs played in Alpine CD players.



Transparent Sheet

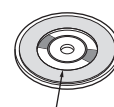

Disc Stabilizer

### On handling Compact Discs (CD/CD-R/CD-RW)

- Do not touch the surface.
- Do not expose the disc to direct sunlight.
- Do not affix stickers or labels.
- Clean the disc when it is dusty.
- Make sure that there are no bumps around the disc.
- Do not use commercially available disc accessories.

**Do not leave the disc in the car or the unit for a long time. Never expose the disc to direct sunlight.** Heat and humidity may damage the CD and you may not be able to play it again.

### To customers using CD-R/CD-RW

- If a CD-R/CD-RW cannot be played back, make sure the last recording session was closed (finalized).
- Finalize the CD-R/CD-RW if necessary, and attempt playback again.

### About media that can be played

Use only compact discs with the label side showing the CD logo marks below.



If you use unspecified compact discs, correct performance cannot be guaranteed.

You can play CD-Rs (CD-Recordables)/CD-RWs (CD-ReWritables) which have been recorded only on audio devices. You can also play CD-Rs/CD-RWs containing MP3/WMA/AAC formatted audio files.

- Some of the following CDs may not play on this unit: Flawed CDs, CDs with fingerprints, CDs exposed to extreme temperatures or sunlight (e.g., left in the car or this unit), CDs recorded under unstable conditions, CDs on which a recording failed or a re-recording was attempted, copy-protected CDs which do not conform to the audio CD industry standard.
- Use discs with MP3/WMA/AAC files written in a format compatible with this unit. For details, refer to "About MP3/WMA/AAC" on page 14.
- ROM data other than audio files contained in a disc will not produce sound when played back.

---

## Protecting the USB connector

- Only a USB Memory, iPhone/iPod or Portable audio player can be connected to the USB connector on this unit. Correct performance using other USB products cannot be guaranteed.
- If the USB connector is used, be sure to use a USB extension cable (supplied). A USB hub is not supported.
- Depending on the connected USB Memory device, the unit may not function or some functions may not be performed.
- The audio file format that can be played back on the unit is MP3/WMA/AAC.
- Artist/song name, etc., can be displayed. Certain, special characters may not be correctly displayed.

---

## On Handling USB Memory

### CAUTION

**Alpine accepts no responsibility for lost data, etc., even if data, etc. is lost while using this product.**

- To prevent malfunction or damage, note the following points.  
Read the USB Memory Owner's Manual thoroughly.  
Do not touch the terminals by hand or metal.  
Do not subject USB Memory to excessive shock.  
Do not bend, drop, disassemble, modify or soak in water.
- Avoid usage or storage in the following locations:  
Anywhere in the car exposed to direct sunlight or high temperatures.  
Anywhere the possibility of high humidity or corrosive substances are present.
- Fix the USB Memory in a location where driver operation will not be hindered.
- USB Memory may not function correctly at high or low temperature.
- Use only certified USB Memory. Pay attention that even certified USB Memory, may not function correctly depending on its type or state.
- USB Memory function is not guaranteed. Use USB Memory according to the terms of agreement.
- Depending on the settings of the USB Memory type, memory state or encoding software, the unit may not play back or display properly.
- A file that is copy-protected (copyright protection) cannot be played back.
- USB Memory may take time to start playback. If there is a particular file other than audio in the USB Memory, it may take considerable time before the file is played back or searched.
- The unit can play back "mp3", "wma" or "m4a" file extensions.
- Do not add the above extensions to a file other than audio data. This non-audio data will not be recognized. The resulting playback may contain noise that can damage speakers and/or amplifiers.
- It is recommended to back up important data on a personal computer.
- Do not remove the USB device while playback is in progress. Change SOURCE to something other than USB, then remove the USB device to prevent possible damage to its memory.

---

## On Handling Portable audio player

- The unit can control a Portable audio player with the USB interface. Playable audio file formats are MP3 and WMA.
- Portable audio player function is not guaranteed. Use Portable audio player according to the terms of agreement. Read the Portable audio player Owner's Manual thoroughly.
- Avoid usage or storage in the following locations:  
Anywhere in the car exposed to direct sunlight or high temperatures.  
Anywhere the possibility of high humidity or corrosive substances are present.
- Fix the Portable audio player in a location where driver operation will not be hindered.
- Portable audio player may not function correctly at high or low temperature.

- Depending on the settings of the Portable audio player type, memory state or encoding software, the unit may not play back or display properly.
- If the Portable audio player has an MSC/MTP setting, set to MTP.
- A Portable audio player in which data is stored by USB Mass Storage may not be playable on the unit.
- Depending on the Portable audio player settings, USB Mass Storage may be supported. For setting, refer to the Owner's Manual of the player.
- The unit can play back MP3/WMA files synchronized by Windows Media Player (Ver. 7, 8, 9), and are then forwarded to the player. The "mp3" or "wma" extensions are playable.
- If data is not synchronized by Windows Media Player and is forwarded in another way, the unit may not be able to correctly play back the files.
- A file that is copy-protected (copyright protection) cannot be played back.
- It is recommended to back up important data on a personal computer.
- Do not remove the USB device while playback is in progress. Change SOURCE to something other than USB, then remove the USB device to prevent possible damage to its memory.

- *Windows Media and the Windows logo are trademarks, or registered trademarks of Microsoft Corporation in the United States and/or other countries.*
- *iPod and iTunes are trademarks of Apple Inc., registered in the U.S. and other countries.*
- *iPhone is a trademark of Apple Inc.*
- *"Made for iPod" means that an electronic accessory has been designed to connect specifically to iPod and has been certified by the developer to meet Apple performance standards.*
- *"Works with iPhone" means that an electronic accessory has been designed to connect specifically to iPhone and has been certified by the developer to meet Apple performance standards.*
- *Apple is not responsible for the operation of this device or its compliance with safety and regulatory standards.*
- *The BLUETOOTH word mark and logos are owned by the Bluetooth SIG, Inc. and any use of such marks by Alpine Electronics, Inc. is under license.*
- *HD Radio™ and the HD and HD Radio Ready logos are proprietary trademarks of iBiquity Digital Corp.*
- *"MPEG Layer-3 audio coding technology licensed from Fraunhofer IIS and Thomson."*
- *"Supply of this product only conveys a license for private, non-commercial use and does not convey a license nor imply any right to use this product in any commercial (i.e. revenue-generation) real time broadcasting (terrestrial, satellite, cable and/or any other media), broadcasting/streaming via internet, intranets and/or other networks or in other electronic content distribution systems, such as pay-audio or audio-on-demand applications. An independent license for such use is required. For details, please visit <http://www.mp3licensing.com>"*
- *Audyssey MultEQ XT is a registered trademark of Audyssey Laboratories, Inc.*



# Getting Started

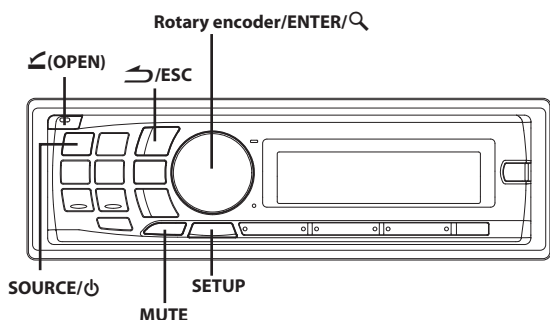

## Accessory List

• Head unit .....	1
• Power cable.....	1
• USB Cable.....	1
• Interface cable for iPod.....	1
• Mounting sleeve.....	1
• Carrying case .....	1
• Bracket key .....	2
• Screw (M5 × 8) .....	4
• Remote Control .....	1
• Battery (AAA size).....	2
• Owner's Manual.....	1 set

## Turning Power On and Off

- 1 Press **SOURCE/POWER** to turn on the unit.

**Note**

- The unit can be turned on by pressing any other button.

- 1 Press and hold **SOURCE/POWER** for at least 2 seconds to turn off the unit.

**Note**

- The first time power is turned on, the volume will start from level 12.

## Source Selection

- 1 Press **SOURCE/POWER** to change the source.  
TUNER → XM/SIRIUS\*1 → DISC → USB\*2/USB iPod\*3 → AUX+\*4 → Bluetooth Audio\*5 → CHANGER\*6 → TUNER

- \*1 Only when XM Radio or SIRIUS Radio is connected.
- \*2 Displayed only when no iPhone/iPod is connected.
- \*3 Displayed only when the iPhone/iPod is connected.
- \*4 Displayed only when the AUX+ SETUP is set to ON, refer to "Setting the AUX+ Setup Mode" on page 22.
- \*5 Displayed only when Bluetooth IN is set to ADAPTER, refer to "Setting the BLUETOOTH Connection" on page 21.
- \*6 Only when the CD changer is connected.

## Detaching and Attaching the Front Panel

### Detaching

- 1 Turn off the unit power.
- 2 Press **(OPEN)** to open the front panel (figure 1).  
To close the front panel, press the left side until it locks as shown in the figure 2.



figure 1

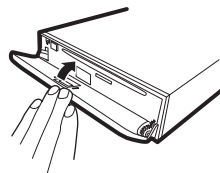
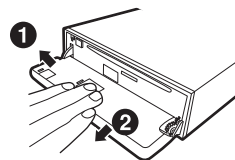

figure 2

- 3 Grasp the front panel firmly, slide to the left ①, and then pull ② to remove.



**Notes**

- The front panel may become hot in normal usage (especially the connector terminals on the back of the front panel). This is not a malfunction.
- To protect the front panel, place it in the supplied carrying case.
- When detaching the front panel, do not apply excessive force as it may result in malfunction.
- Do not leave the front panel open, or drive the car with the panel open as it may result in an accident or malfunction.

### Attaching

- 1 Insert the right side of the front panel into the main unit. Align the groove on the front panel with the projections on the main unit.
- 2 Push the left side of the front panel until it locks firmly into the main unit.

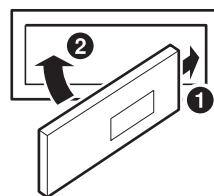

**Notes**

- Before attaching the front panel, make sure that there is no dirt or dust on the connector terminals and no foreign object between the front panel and the main unit.
- Attach the front panel carefully, holding the sides of the front panel to avoid pushing buttons by mistake.

---

## Initial System Start-Up

---

Be sure to press the RESET switch when using the unit for the first time, after changing the car battery, etc.

- 1 Turn off the unit power.
- 2 Press **⏏** (OPEN) to open the front panel, and then remove it.
- 3 Press **RESET** with a ballpoint pen or similar pointed object.

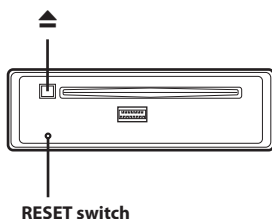

---

## Adjusting Volume

---

- 1 Turn the **Rotary encoder** until the desired sound is obtained.

---

## Lowering Volume Quickly

---

Activating the Audio Mute function will instantly lower the volume level by 20 dB.

- 1 Press **MUTE** to activate/deactivate the MUTE mode.

---

## Setting the Time and Calendar

---

- 1 Press and hold **SETUP** for at least 2 seconds to activate the **SETUP selection mode**.

- 2 Turn the **Rotary encoder** to select the **General mode**, and then press **ENTER/Q**.

Bluetooth<sup>\*1</sup> ↔ General ↔ Display ↔ Tuner<sup>\*2</sup>/HD Radio<sup>\*3</sup> ↔ XM<sup>\*4</sup>/SIRIUS<sup>\*5</sup> ↔ Bluetooth

\*1 Displayed only when **INT Mute** is OFF, and the mode is set to other than **Bluetooth Audio**.

\*2 Not displayed when **HD Radio Tuner module** is connected.

\*3 Only when **HD Radio Tuner module** is connected.

\*4 Only when **XM Radio** is connected.

\*5 Only when **SIRIUS Radio** is connected.

- 3 Turn the **Rotary encoder** to select **Clock Adjust**, and then press **ENTER/Q**.

- 4 Turn the **Rotary encoder** to set year.

- 5 Press **ENTER/Q**.

- 6 Repeat steps 4 and 5 above to set month, day, hour and minute.

- 7 Press and hold **SETUP** for at least 2 seconds to return to normal mode.

### Notes

- Pressing **↶/ESC** returns to the previous **SETUP** mode.
- If no operation is performed for 60 seconds, **SETUP** is canceled.
- To synchronize the clock to another clock/watch or radio time announcement, press and hold **ENTER/Q** for at least 2 seconds after setting the "hour". Minutes will reset to 00. If the display shows over "30" minutes when you do this, the time will advance one hour.

# Radio

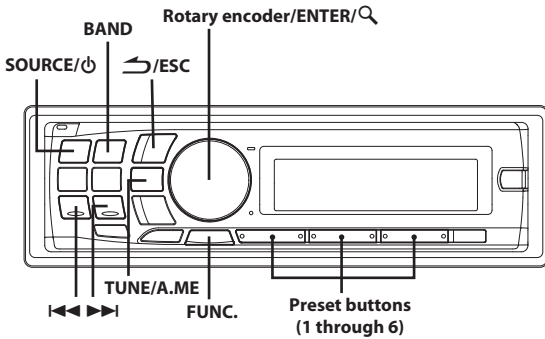

This unit cannot receive HD Radio signals (digital terrestrial radio). In order to activate the digital radio functions described below, an optional HD Radio Tuner module must be connected through the Ai-NET bus. iTunes Tagging lets you tag songs you hear on HD Radio stations with your new CDA-117 and then preview, buy, and download them later from your iTunes Tagged playlist the next time you sync your iPhone/iPod. If the unit is connected to a Tagging compatible device, you can use the iTunes Tagging function. For details, refer to the Owner's Manual of the Tagging compatible device.

## Listening to Radio

- 1 Press **SOURCE/🔌** to select TUNER mode.
- 2 Press **BAND** repeatedly until the desired radio band is displayed.  
FM1 → FM2 → AM → FM1
- 3 Press **TUNE/A.ME** to select the tuning mode.  
DX (Distance mode) → LOCAL (Local mode) → MANUAL (Manual mode) → DX

### Note

- The initial mode is Distance mode.

### Distance mode:

Both strong and weak stations will be automatically tuned in (Automatic Seek Tuning).

### Local mode:

Only strong stations will be automatically tuned in (Automatic Seek Tuning).

### Manual mode:

The frequency is manually tuned in steps (Manual tuning).

- 4 Press **🔍** or **▶▶** to tune in the desired station.  
Holding down **🔍** or **▶▶** will change the frequency continuously.

### Note

- If Digital Seek is set to ON, the SEEK UP/DOWN functions only stop on digital station frequencies while receiving an HD Radio signal. Refer to "Digital Seek ON/OFF Setting" on page 25.

## Presetting Stations Manually

- 1 Tune in the station you want to store. Press and hold, for at least 2 seconds, any one of the preset buttons (1 through 6) into which you wish to store the station.  
The display shows the band, preset number and station frequency memorized.

### Notes

- A total of 18 stations can be stored in the preset memory (6 stations for each band; FM1, FM2 and AM).
- If you store a station in a preset memory which already has a station, the current station will be cleared and replaced with the new station.
- If the (F) indicator is illuminated, turn off the indicator by pressing **FUNC.**, then you can perform the operation.

## Presetting Stations Automatically

- 1 Press **BAND** repeatedly until the desired radio band is displayed.
- 2 Press and hold **TUNE/A.ME** for at least 2 seconds.  
The frequency on the display continues to change while the automatic memory is in progress. The tuner will automatically seek and store 6 strong stations in the selected band. They will be stored into preset buttons 1 to 6 in order of signal strength. When the automatic memory has been completed, the tuner goes to the station stored in preset location No.1.

### Note

- If no stations are stored, the tuner will return to the original station you were listening to before the auto memory procedure began.

## Tuning to Preset Stations

- 1 Select the desired band, then press any one of the station preset buttons (1 through 6) that has your desired radio station in memory.  
The display shows the band, preset number and frequency of the station selected.

### Note

- If the (F) indicator is illuminated, turn off the indicator by pressing **FUNC.**, then you can perform the operation.

## Frequency Search Function

You can search for a radio station by its frequency.

- 1 Press and hold **ENTER/🔍** for at least 2 seconds in Radio mode to activate Frequency search mode.
- 2 Turn the **Rotary encoder** to select the desired frequency.
- 3 Press **ENTER/🔍** to receive the selected frequency.\*

\* Operation is not required during HD Radio reception.

### Note

- Press **↶/ESC** in the search mode to cancel. Or, the search mode will be canceled if no operation is performed for 10 seconds.

## Receiving a Multicast Station (HD Radio™ mode only)

Multicasting is the Ability to broadcast multiple program streams over a single FM frequency. This increases the amount and diversity of content choices. A maximum of eight multicast station channels can be selected on this unit.

When multicast station is received, the program number and the SPS indicator lights up.

### 1 Press ◀ or ▶ to select the desired program service.

Receiving the Multicast Station Program Service.

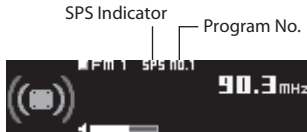

#### Program Service example:

Multicast Radio Station	Program No.	Program Service
90.3 MHz	No.1	MPS: Main Program Service
90.3 MHz	No.2	SPS: Sub-program Service
90.3 MHz	No.3	SPS: Sub-program Service
90.3 MHz	No.4	SPS: Sub-program Service
90.3 MHz	No.5	SPS: Sub-program Service
90.3 MHz	No.6	SPS: Sub-program Service
90.3 MHz	No.7	SPS: Sub-program Service
90.3 MHz	No.8	SPS: Sub-program Service

## RBDS

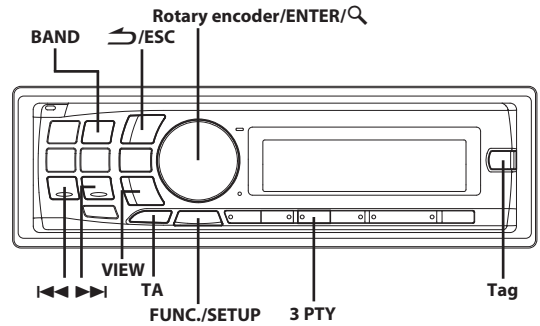

The RBDS (Radio Broadcast Data System) is a radio information system. The RBDS allows you to receive a variety of information such as traffic information, station names.

#### The RBDS digital data includes the following:

PS	Program Service Name
TP	Traffic Program
TA	Traffic Announcement

## Setting the Time to automatically Adjust

When you set to ON, the time is automatically adjusted by RBDS data.

### 1 Press and hold **SETUP** for at least 2 seconds to activate the **SETUP** mode.

### 2 Turn the **Rotary encoder** to select the **Tuner** mode, and then press **ENTER/🔍**.

Bluetooth<sup>\*1</sup> ↔ General ↔ Display ↔ Tuner<sup>\*2</sup>/HD Radio<sup>\*3</sup> ↔ XM<sup>\*4</sup>/SIRIUS<sup>\*5</sup> ↔ Bluetooth

\*1 Displayed only when INT Mute is OFF, and the mode is set to other than Bluetooth Audio.

\*2 Not displayed when HD Radio Tuner module is connected.

\*3 Only when HD Radio Tuner module is connected.

\*4 Only when XM Radio is connected.

\*5 Only when SIRIUS Radio is connected.

### 3 Turn the **Rotary encoder** to select **Auto Clock**, and then press **ENTER/🔍**.

### 4 Turn the **Rotary encoder** to select **ON** or **OFF**.

### 5 Press and hold **SETUP** for at least 2 seconds to return to normal mode.

#### Notes

- Pressing ↵/ESC during the procedure will return to the previous mode.
- If no operation is performed for 60 seconds in the SETUP mode, the setting mode is canceled.

---

## Receiving Traffic Information

---

- 1 Press and hold **TA** for at least 2 seconds so that the “TA” indicator lights up.
- 2 Press **◀** or **▶** to select your desired traffic information station.  
When a traffic information station is tuned in, the “TP” indicator lights up.  
Traffic information is heard only when it is being broadcast. If traffic information is not being broadcast, the unit is set in the standby mode. When a traffic information broadcast begins, the unit automatically receives it and the display shows “T. INFO”. When the traffic information broadcast is over, the unit will automatically set in the standby mode.

### Notes

- If the traffic information broadcast signal falls below a certain level, the unit remains in the receiving mode for 1 minute. If the signal remains below a certain level for over 1 minute, the “TA” indicator blinks.
- If you do not want to listen to the traffic information being received, lightly press **BAND** to skip that traffic information message. The TA mode will remain in the ON position to receive the next traffic information message.
- If the volume level is changed while receiving traffic information, the changed volume level will be memorized. When traffic information is received next time, the volume level will be automatically adjusted to the level memorized.
- In the TA mode, the SEEK tuning selects only the TP stations.

---

## PTY (Program Type) Tuning

---

- 1 Press **FUNC.** so that the (F) indicator lights up.
- 2 Press **3 PTY** to activate the PTY mode, while the unit is in **Radio (FM receiving) mode**.  
The Program Type of the station being currently received will be displayed for 5 seconds.  
If there is no receivable PTY broadcast, “No PTY” will be displayed for 5 seconds.  
If no RBDS station can be received, the display shows “No PTY”.  
**Note**
  - If no operation is performed for 5 seconds after pressing **3 PTY**, the PTY mode will be automatically canceled.
- 3 Press **◀** or **▶** within 5 seconds after activating the PTY mode to choose the desired program type while the PTY (program type) is being displayed.  
Each press scrolls the program type by one.
- 4 Press **3 PTY** within 5 seconds after selecting the program type to start searching for a station in the selected program type.  
The chosen program type display blinks during searching and lights when a station is found.  
If no PTY station is found, “No PTY” will be displayed for 5 seconds.
- 5 Press **FUNC.** to activate the normal mode.  
The (F) indicator goes out.

### Note

- Operate the unit while the (F) indicator lights up. If no operation is performed for 5 seconds, the (F) indicator goes out.

---

## Receiving Traffic Information While Playing CD or Radio

---

- 1 Press and hold **TA** for at least 2 seconds so that the “TA” indicator lights up.
- 2 Press **◀** or **▶** to select a traffic information station if necessary.  
When a traffic information broadcast starts, the unit automatically mutes the CD player or the regular FM broadcast. When the traffic information broadcast finishes, the unit automatically returns to the original source play before the traffic information broadcast began.  
**When traffic information stations cannot be received:**  
**In the tuner mode:**  
When the TP signal can no longer be received for over 1 minute, the “TA” indicator blinks.  
**In the CD mode:**  
When the TP signal can no longer be received, the traffic information station of another frequency will be selected automatically.
- 3 Press and hold **TA** for at least 2 seconds to deactivate the **Traffic Information mode**.  
The “TA” indicator goes out.

---

## Using iTunes tagging

---

iTunes Tagging lets you tag songs you hear on RBDS stations with your new CDA-117 and then preview, buy, and download them later from your iTunes Tagged playlist the next time you sync your iPhone/iPod.

### Note

- For details on the iPhone/iPod models usable with this unit, refer to “Connecting an iPhone/iPod” on page 32.

- 1 **Tune in the desired RBDS station.**  
If there is tag information, “Tag” appears in the display.
- 2 **Press Tag while desired song is broadcasting.**  
The “Tag” blinks at the same time the unit beeps for 2 times and “Tagging ...” is displayed.
- 3 **When completed, “Tag stored” is displayed and the “Tag” indicator lights up at the same time the unit beeps for 2 times\*.**  
*\* When completed, “Tag count X” (X is the total amount of stored tag information) is displayed if no iPhone/iPod is connected.*

### Notes

- When Beep is set to OFF, there will be no beep sound during operation. For details, refer to “Sound (Beep) Guide Function” on page 21.
- During tagging, the iPhone/iPod takes priority to save the tag information. If no iPhone/iPod is connected, the tag information is saved to this unit.
- When the memory of iPhone/iPod is full, “iPod Memory Full” is displayed and the unit beeps 2 times. The tag information will be stored to the unit.
- During tagging, changing the source or RBDS station or traffic information, etc., is received, the tagging will be canceled; however, “Cannot Tag” will not be displayed in this case.
- This unit can store up to 50 pieces of tag information. When the memory of the unit is full, “Tuner Memory Full Connect iPod” may be displayed and the unit beeps 2 times.

- When an iPod that doesn't support the tagging function is connected, "Non-Tagging iPod" may be displayed.
- When the iPhone/iPod is disconnected from the unit during tagging, its tag information will be stored in the unit.
- If there is stored tag information on the unit, when an iPhone/iPod supporting the tag function is connected, the stored tag information will be transferred to the iPhone/iPod automatically. When the iPhone/iPod memory becomes full, "iPod Memory Full" will be displayed, and any remaining tag information on the unit will not be transferred to the iPhone/iPod.
- If tag information already exists, "Already Tagged" will be displayed when you try to tag information again.
- Tagging may be canceled by changing the frequency or station, and the message "Cannot Tag", etc., may not be displayed.
- If a song is tagged and the remaining storage volume of the connected iPhone/iPod is sufficient to hold the song's tag information, it will be saved on the iPhone/iPod.

## Displaying Radio Text

Text messages from a radio station can be displayed.

- 1 Press **VIEW** while receiving FM in the radio mode to select the Radio Text display.

The display will change every time the button is pressed. For details, refer to "Displaying the Text" on page 18.

## CD/MP3/WMA/AAC

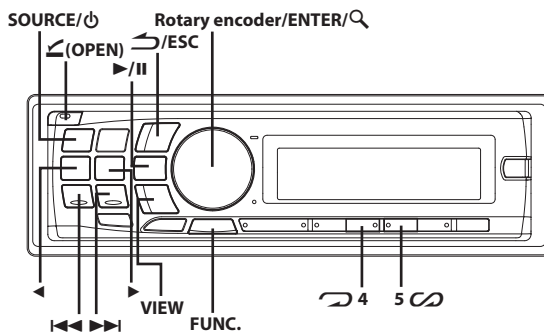

## Playback

- 1 Press **(OPEN)**.  
The front panel will open.
- 2 Insert a disc with the label side facing up.  
The disc will be pulled into the unit automatically.

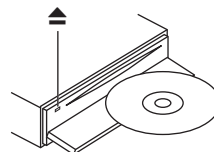

### Note

- When a disc is already inserted, press **SOURCE/⏻** to switch to the DISC mode.

- 3 While playing back MP3/WMA/AAC, press **◀** or **▶** to select the desired folder.  
Pressing and holding **◀** or **▶** will change folders continuously.
  - 4 Press **◀◀** or **▶▶** to select the desired track (file).  
Pressing and holding **◀◀** or **▶▶** will fast backward/fast forward track continuously.
- Note**
- If a song is fast reversed to its beginning in pause mode, the song will be played back automatically.
- 5 To pause playback, press **>||**.  
Pressing **>||** again will resume playback.
  - 6 After pressing **(OPEN)** to open the front panel, press **▲** to eject the disc.

### Notes

- Do not remove a CD during its eject cycle. Do not load more than one disc at a time. A malfunction may result from doing either.
- Three-inch (8 cm) CDs cannot be used.
- WMA format files that are protected by DRM (Digital Rights Management), AAC format files that have been purchased from iTunes Store and files that are copy-protected (copyright protection) cannot be played back on this unit.
- The track display for MP3/WMA/AAC data playback is the file numbers recorded on the disc.

- The playback time may not be correctly displayed when a VBR (Variable Bit Rate) recorded file is played back.
- Press **VIEW** to switch the display. For details, refer to "Displaying the Text" on page 18.

## Repeat Play

### 1 Press **↶** 4.

The song is played back repeatedly.

RPT\*<sup>1</sup> → RPT □\*<sup>2</sup> → RPT ⊙\*<sup>3</sup> → (off) → RPT

- \*1 Only a track/file is repeatedly played back.
- \*2 Only files in a folder are repeatedly played back (MP3/WMA/AAC mode only).
- \*3 A disc is repeatedly played back (When a CD changer is connected.).

#### Notes

- If RPT is set to ON during M.I.X. play in CD changer mode, M.I.X. will apply to the current disc only.
- If a CD changer or an MP3 compatible CD changer is connected: Press **FUNC.** to select the desired function (RPT/M.I.X.). Perform this operation within 5 seconds.

### 2 To cancel repeat play, select (off) with the above procedure.

## M.I.X. (Random Play)

### 1 Press 5 **∞**.

The songs are played back in random sequence.

MIX\*<sup>1</sup> → MIX □\*<sup>2</sup> → MIX ⊙\*<sup>3</sup> → (off) → MIX

- \*1 The tracks are played back in random sequence (CD mode only).
- \*2 Only files in a folder are played back in random sequence (MP3/WMA/AAC mode only).
- \*3 For CD, the tracks on all the CDs in the current magazine will be included in the random playback sequence. (When a CD changer equipped with the ALL M.I.X. function is connected.); For MP3/WMA/AAC, files are played back in random sequence. If an MP3 compatible CD changer is connected, all files in a disc are played back in random sequence, and playback shifts to the next disc.

#### Note

- If M.I.X. is set to ON during RPT ⊙ (REPEAT ALL) play in CD changer mode, M.I.X. will apply to the current disc only.

### 2 To cancel M.I.X. play, select (off) with the above procedure.

#### Note

- If a CD changer or an MP3 compatible CD changer is connected: Press **FUNC.** to select the desired function (RPT/M.I.X.). Perform this operation within 5 seconds.

## Searching for CD Text

On discs utilizing CD Text, songs can be searched and played by using their recorded titles. For discs without CD Text, searches are made using the track numbers associated with each song.

### 1 Press **ENTER/Q** during play.

This will set the search mode.

### 2 Turn the Rotary encoder to select the desired track, and then press **ENTER/Q**.

This will play the selected track.

#### Notes

- Press **↶/ESC** in the search mode to cancel. Or, the search mode is canceled if no operation is performed for 60 seconds.
- When CD Text Search is made during M.I.X. play, the M.I.X. play mode will be canceled.
- In CD changer mode, searches can only be made using the track numbers associated with each song, even though discs utilize CD text.

## Folder/File Name Search (Concerning MP3/WMA/AAC)

Folder and file names may be searched and displayed during playback.

### Folder Name Search mode

#### 1 During MP3/WMA/AAC playback, press **ENTER/Q** to activate the search mode.

#### 2 Turn the Rotary encoder to select Folder Name Search mode, and then press **ENTER/Q**.

#### 3 Turn the Rotary encoder to select the desired folder.

#### 4 Press and hold **ENTER/Q** for at least 2 seconds to play back the first file in the selected folder.

#### Notes

- Press and hold **↶/ESC** for at least 2 seconds in the search mode to cancel. Or, the search mode is canceled if no operation is performed for 60 seconds.
- To search for files in the Folder Name Search mode, press **ENTER/Q**. Files in the folder may be searched.
- Press **◀** or **▶** to select folders in which to search for a file.
- Press **↶/ESC** to exit Folder Name Search mode in step 3 in order to select File Name Search mode.
- When Folder Name Search is made during M.I.X. play, the M.I.X. play mode will be canceled.
- The root folder of a disc is displayed as "\ROOT".

### File Name Search mode

#### 1 During MP3/WMA/AAC playback, press **ENTER/Q** to activate the search mode.

#### 2 Turn the Rotary encoder to select File Name Search mode, and then press **ENTER/Q**.

#### 3 Select the desired file by turning the Rotary encoder.

#### 4 Press **ENTER/Q** to play back the selected file.

#### Notes

- Press and hold **↶/ESC** for at least 2 seconds in the search mode to cancel. Or, the search mode is canceled if no operation is performed for 60 seconds.
- Press **↶/ESC** in the search mode to return to the previous mode.
- When File Name Search is made during M.I.X. play, the M.I.X. play mode will be canceled.

---

## Quick Search

---

You can search for tracks (files).

**1** Press and hold **ENTER/** for at least 2 seconds in the CD/MP3/WMA/AAC mode to activate Quick Search mode.

**2** Turn the Rotary encoder to select a desired track (file).  
The selected track is played back immediately.

### Notes

- Press **ESC** in the search mode to cancel. Or, the search mode is canceled if no operation is performed for 10 seconds.
- When Quick Search is made during M.I.X. play, the M.I.X. play mode will be canceled.

---

## Search Position Memory

---

During playback, you can quickly return to the last-selected hierarchy level in the search mode.

**1** Press **ESC**.  
The hierarchy you selected last in the search mode is displayed.

---

## About MP3/WMA/AAC

---

### CAUTION

**Except for private use, duplicating audio data (including MP3/WMA/AAC data) or distributing, transferring, or copying it, whether for free or for a fee, without permission of the copyright holder is strictly prohibited by the Copyright Act and by international treaty.**

#### What is MP3?

MP3, whose official name is "MPEG-1 Audio Layer 3," is a compression standard prescribed by the ISO, the International Standardization Organization and MPEG which is a joint activity institution of the IEC. MP3 files contain compressed audio data. MP3 encoding is capable of compressing audio data at extremely high ratios, reducing the size of music files to as much as one-tenth their original size. This is achieved while still maintaining near CD quality. The MP3 format realizes such high compression ratios by eliminating the sounds that are either inaudible to the human ear or masked by other sounds.

#### What is WMA?

WMA, or "Windows Media™ Audio," is compressed audio data. WMA is similar to MP3 audio data and can achieve CD quality sound with small file sizes.

#### What is AAC?

AAC is the abbreviation for "Advanced Audio Coding," and is a basic format of audio compression used by MPEG2 or MPEG4.

#### Method for creating MP3/WMA/AAC files

Audio data is compressed using software with MP3/WMA/AAC codecs. For details on creating MP3/WMA/AAC files, refer to the user's manual for that software.

MP3/WMA/AAC files that are playable on this device have the file extensions "mp3"/"wma"/"m4a". Files with no extension cannot be played back (WMA ver. 7, 8 and 9 are supported). Protected files are not supported, neither are raw AAC files (using the ".aac" extension). There are many different versions of the AAC format. Confirm that the software being used conforms to the acceptable formats listed above. It's possible that the format may be unplayable even though the extension is valid.  
Playback of AAC files encoded by iTunes is supported.

#### Supported playback sampling rates and bit rates

##### MP3

Sampling rates: 48 kHz, 44.1 kHz, 32 kHz, 24 kHz, 22.05 kHz, 16 kHz  
Bit rates: 8 - 320 kbps

##### WMA

Sampling rates: 48 kHz, 44.1 kHz, 32 kHz  
Bit rates: 48 - 192 kbps

##### AAC

Sampling rates: 48 kHz, 44.1 kHz, 32 kHz, 24 kHz, 22.05 kHz, 16 kHz, 12 kHz, 11.025 kHz, 8 kHz  
Bit rates: 16 - 320 kbps

This device may not play back correctly depending on sampling rates. In the USB mode, the playback time may not be correctly displayed when a VBR (Variable Bit Rate) recorded file is played back.

#### ID3 tags/WMA tags

This device supports ID3 tag v1 and v2, and WMA/AAC tag. If tag data is in an MP3/WMA/AAC file, this device can display the title (track title), artist name, and album name ID3 tag/WMA/AAC tag data. This device can only display single-byte alphanumeric characters (up to 30 for ID3 tags and up to 15 for WMA tags) and the underscore. For non-supported characters, "No Support" is displayed. If information contains characters other than ID3 tag information, the audio file may not be played back. The tag information may not be correctly displayed, depending on the contents.

#### Playing back MP3/WMA/AAC

MP3/WMA/AAC files are prepared, then written to a CD-R, CD-RW using CD-R writing software or stored to a USB Memory. A disc can hold up to 510 files/folders (including Root Folders), and the maximum number of folders is 255. This unit can recognize at most 20 Banks (1,000 files per Bank) stored in USB Memory/Portable audio player. Playback may not be performed if a disc or USB Memory exceeds the limitations described above. Do not make a file's playback time more than 1 hour.

#### Media supported

The media that this device can play back are CD-ROMs, CD-Rs, and CD-RWs.  
This device also can play back USB Memory media.

#### Corresponding File Systems

This device supports discs formatted with ISO9660 Level 1 or Level 2. Under the ISO9660 standard, there are some restrictions to remember. The maximum nested folder depth is 8 (including the root directory). The number of characters for a folder/file name is limited. Valid characters for folder/file names are letters A-Z (all caps), numbers 0-9, and '\_' (underscore).  
This device also can play back discs in Joliet, Romeo, etc., and other standards that conform to ISO9660. However, sometimes the file names, folder names, etc., are not displayed correctly.  
This device also supports FAT 12/16/32 for USB Memory device.

#### Formats supported

This device supports CD-ROM XA, Mixed Mode CD, Enhanced CD (CD-Extra) and Multi-Session.  
This device cannot correctly play back discs recorded with Track At Once or packet writing.

#### Order of files

Files are played back in the order that the writing software writes them to the disc. Therefore, the playback order may not be what is expected.



Verify the writing order in the software's documentation. The playback order of the folders and files is as follows.

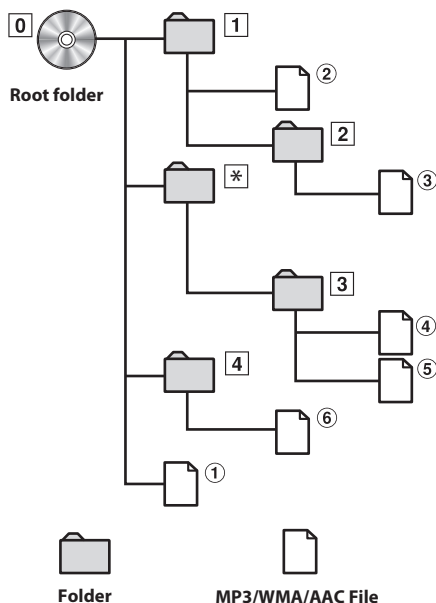

\* The folder No./ folder Name will not be displayed if no file is contained in the folder.

## Terminology

### Bit rate

This is the "sound" compression rate specified for encoding. The higher the bit rate, the higher the sound quality, but also the larger the files.

### Sampling rate

This value shows how many times per second the data is sampled (recorded). For example, music CDs use a sampling rate of 44.1 kHz, so the sound is sampled (recorded) 44,100 times per second. The higher the sampling rate, the higher the sound quality, but also the larger the volume of data.

### Encoding

Converting music CDs, WAVE (AIFF) files, and other sound files into the specified audio compression format.

### Tag

Song information such as track titles, artist names, album names, etc., written into MP3/WMA/AAC files.

### Root folder

The root folder (or root directory) is found at the top of the file system. The root folder contains all folders and files. It is created automatically for all burned discs.

# Sound Setting

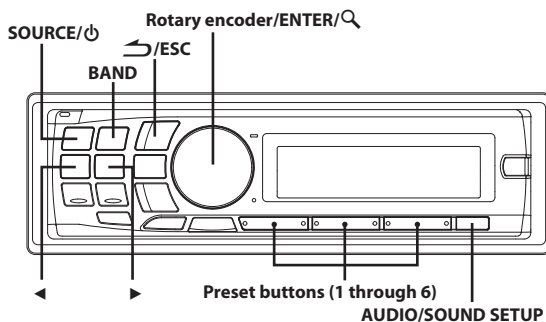

## Adjusting Subwoofer Level/Balance (Between Left and Right)/Fader (Between Front and Rear)/Black Out/Defeat

1 Press **AUDIO** repeatedly to choose the desired mode.

Each press changes the mode as follows:

SUBWOOFER\*1 → BALANCE → FADER → BLACK OUT\*2 → DEFEAT → VOLUME → SUBWOOFER

\*1 When the subwoofer mode is set to OFF, its level cannot be adjusted, refer to "Turning Subwoofer ON/OFF" on page 16.

\*2 When Blackout mode is turned on, after 5 seconds, all display indications on this unit will turn off to reduce power consumption. This additional power enhances the sound quality.

Subwoofer level	0 ~ 15
Balance	-15 (L) ~ 15 (R)
Fader	-15 (R) ~ 15 (F)
Black Out	ON/OFF
Defeat	ON/OFF
Volume	0 ~ 35

### Notes

- If no operation is performed for 5 seconds after selecting the SUBWOOFER, BALANCE, FADER, BLACK OUT or DEFEAT mode, the unit automatically returns to normal mode.
- If any button on the unit is pressed during the Blackout Mode, the function is displayed for 5 seconds before returning to Blackout mode.

2 Turn the **Rotary encoder** until the desired sound is obtained in each mode.

### Note

- Depending on the connected devices, some functions and display indications do not work.

## Sound Setting

You can flexibly customize the unit to suit your own preference and usage. From the SOUND SETUP menu, Audio Setting can be modified.

**Use steps 1 to 4 to select one of the setting modes to modify. See the applicable section below for details about the selected setting item.**

- 1 Press and hold **SOUND SETUP** for at least 2 seconds to activate the Sound Setting mode.
- 2 Turn the **Rotary encoder** to select the desired sound setting menu, and then press **ENTER/↻**.  
HPF\*1 ↔ Subwoofer ↔ SUBW. System\*2 ↔ SUBW. Phase\*2 ↔ SUBW. Channel\*2 ↔ Media Xpander ↔ MX Level\*3 ↔ EQ Mode ↔ TCR Parameter ↔ Sound Field\*4 ↔ HPF
  - \*1 Adjustment cannot be performed when an external audio processor is connected or Defeat is set to ON.
  - \*2 These functions are inoperable when Subwoofer is set to OFF.
  - \*3 This function is effective only when Media Xpander is set to ON.
  - \*4 In step 2, two sound adjustment items (Parametric EQ/Graphic EQ, T.Correction) can be selected in Sound Field Adjustment mode, turn the **Rotary encoder** to select the desired item, and then press **ENTER/↻** to continue to step 3.
- 3 Turn the **Rotary encoder** to change the setting, and then press **ENTER/↻**.  
(e.g. Select Subwoofer ON or Subwoofer OFF)
- 4 Press and hold **↵/ESC** for at least 2 seconds to return to normal mode.

### Notes

- Media Xpander, Parametric EQ/Graphic EQ Adjustment, EQ Mode and MX Level Adjustment are inoperable when Defeat is set to ON.
- Pressing **↵/ESC** returns to the previous Sound menu mode.
- If no operation is performed for 60 seconds, Sound menu mode is canceled.

## Adjusting the High Pass Filter

The High Pass Filter on this unit can be adjusted to suit your personal taste.

**Setting item:** HPF

### Setting contents:

OFF (Initial setting) / 60 Hz / 80 Hz / 100 Hz

## Turning Subwoofer ON/OFF

When the subwoofer is on, you can adjust the subwoofer output level (refer to "Sound Setting" on page 16).

**Setting item:** Subwoofer

### Setting contents:

ON (Initial setting) / OFF

#### ON:

The subwoofer signal is output from the Subwoofer RCA Connectors (refer to "Connections" on page 52).

#### OFF:

No subwoofer signal is output from the Subwoofer RCA Connectors (refer to "Connections" on page 52).

## Setting the Subwoofer System

When the subwoofer is on, you can select either System 1 or System 2 for the desired subwoofer effect.

**Setting item:** SUBW. System

### Setting contents:

SYSTEM 1 (Initial setting) / SYSTEM 2

#### SYSTEM 1:

Subwoofer level changes according to the main volume setting.

#### SYSTEM 2:

Subwoofer level change is different from the main volume setting. For example, even at low volume settings, the subwoofer is still audible.

## Setting the Subwoofer Phase

The subwoofer output phase is toggled SUBWOOFER NORMAL (0°) or SUBWOOFER REVERSE (180°). To adjust the level, turn the **Rotary encoder**.

**Setting item:** SUBW. Phase

### Setting contents:

0° (Initial setting) / 180°

## Setting the Subwoofer Channel (SUBW. Channel)

You can set the subwoofer output to stereo or monaural. Make sure to set the correct output for your subwoofer type.

**Setting item:** SUBW. Channel

### Setting contents:

STEREO (Initial setting) / MONO

#### STEREO:

Subwoofer stereo (L/R) output

#### MONO:

Subwoofer monaural output

## Turning Media Xpander ON/OFF

When the Media Xpander is on, you can adjust the Media Xpander level (refer to "Setting the MX Level" on page 16).

**Setting item:** Media Xpander

### Setting contents:

OFF (Initial setting) / ON

## Setting the MX Level

MX (Media Xpander) makes vocals or instruments sound distinct regardless of the music source. The FM radio, CD, USB Memory and iPhone/iPod, will be able to reproduce the music clearly even in cars with a lot of road noise.

1 Changing the source to which you want to apply Media Xpander.

#### FM (MX level 1 to 3):

The medium to high frequencies become clearer, and produces well balanced sound at all frequencies.

#### CD (MX level 1 to 3):

CD mode processes a large amount of data during playback. MX takes advantage of this large data quantity to reproduce a more clear, clean output.

#### CMPM/SAT (MX level 1 to 3):

This corrects information that was lost at the time of compression. This reproduces a well-balanced sound close to the original.

### DVD (Video CD) (MOVIE MX level 1 to 2):

The dialogue portion of a video is reproduced more clearly.

### (DVD MUSIC):

A DVD or Video CD contains a large quantity of data such as music clip. MX uses this data to reproduce the sound accurately.

### AUX (MX level 1):

Choose the MX mode (CMPM, MOVIE, or MUSIC) that corresponds to the media connected.

### Notes

- Each music source, such as FM radio, CD, and MP3/WMA/AAC can have its own MX setting.
- On disks with both MP3/WMA/AAC and CD-DA, when the source changes from "MP3/WMA/AAC to CD-DA" or "CD-DA to MP3/WMA/AAC", MX-mode switching may delay playback slightly.
- Setting to Non Effect sets MX mode of each music source to OFF.
- The function is inoperable when DEFEAT is set to ON.
- There is no MX mode for AM radio.
- If an audio processor with the MX function (PXA-H701, etc.) is connected, its own MX processing is applied to the music source. Since the processor MX settings may not match the head unit, the audio processor needs to be adjusted. For details, refer to the Owner's Manual of the audio processor.
- "CMPM" is applied for MP3/WMA/AAC and iPhone/iPod.
- "SAT" is applied for XM radio and SIRIUS radio.

## Setting EQ mode

This setting gives you a choice of 5-band parametric, or 7-band graphic equalizer.

### Setting item: EQ Mode

#### Setting contents:

Parametric EQ (Initial setting) / Graphic EQ

#### PEQ:

5-band Parametric EQ

#### GEQ:

7-band Graphic EQ

## Setting the Time Correction Unit (TCR Parameter)

You can change the unit, (cm or inch) of time correction.

### Setting item: TCR Parameter

#### Setting contents:

cm (Initial setting) / inch

## Sound Field Adjustment

The setting of Parametric EQ/Graphic EQ and Time Correction can be adjusted in this mode.

### Adjusting the Parametric Equalizer Curve

You can modify the Equalizer settings to create a response curve more appealing to your personal taste. To adjust the Parametric Equalizer Curve, set the EQ Mode to Parametric EQ. For details, refer to "Setting EQ mode" on page 17.

**1** After selecting Parametric EQ from the Sound Field mode, press **BAND** to select the band to be adjusted.

Band 1 → Band 2 → Band 3 → Band 4 → Band 5 → Band 1

**2** Press ◀ or ▶ to select frequency bands.

Adjustable frequency bands: 63 Hz to 17.5 kHz (in 1/3 octave steps).

Band-1	63 Hz~200 Hz
--------	--------------

Band-2	160 Hz~1 kHz
Band-3	630 Hz~4 kHz
Band-4	1.6 kHz~10 kHz
Band-5	10 kHz~17.5 kHz

**3** Turn the Rotary encoder to adjust the level.

Adjustable level: -6 to +6 dB

**4** Press **SOURCE** /  to set the bandwidth (Q).

Adjustable bandwidth: 1, 2, 3, 4

**5** To adjust another band, repeat steps 1 to 4 and adjust all bands.

### Note

- While adjusting the Parametric EQ, you should consider the frequency response of the connected speakers.

## Adjusting the Graphic Equalizer Curve

You can modify the equalizer settings to create a response curve more appealing to your personal taste. To adjust the graphic equalizer curve, set the EQ Mode to Graphic EQ. For details, refer to "Setting EQ mode" on page 17.

**1** After selecting Graphic EQ from the Sound Field mode, press **BAND** to select the band to be adjusted.

Band 1 → Band 2 → Band 3 → Band 4 → Band 5 → Band 6 → Band 7 → Band 1

Band-1	80 Hz
Band-2	250 Hz
Band-3	500 Hz
Band-4	1 kHz
Band-5	4 kHz
Band-6	8 kHz
Band-7	16 kHz

**2** Turn the Rotary encoder to adjust the level.

Adjustable output level: -6 to +6 dB

**3** To adjust another band, repeat steps 1 and 2, and then adjust all bands.

## Adjusting the Time Correction

Before performing the following procedures, refer to "About Time Correction" on page 39.

**1** After selecting T.Correction from the Sound Field mode, press **BAND** to select a speaker to be adjusted.

F-L\*1 → F-R\*2 → R-L\*3 → R-R\*4 → SW-L → SW-R → F-L

\*1 Front-L (Initial setting)

\*2 Front -R

\*3 Rear-L

\*4 Rear-R

**2** Turn the Rotary encoder to adjust the distance correction value (0.0 to 336.6cm).

L = (distance to farthest speaker) - (distance to other speakers)

**3** Repeat steps 1 and 2 to set another speaker.

By setting these values to make its sound reach the listening position at the same time as the sound of other speakers.

## Storing the Sound Field Adjustment Settings

The Sound Field Settings containing Parametric EQ/Graphic EQ and T.Correction settings can be stored in the preset memory.

- 1 When the settings of Sound Field have been completed, select any one of the **preset buttons (1 through 6)** in any item of the Sound Field mode (e.g. Parametric EQ), press and hold the desired preset buttons for at least 2 seconds.
- 2 Turn the **Rotary encoder** to select PROTECT YES/NO, and then press **ENTER/Q** to store the adjusted contents.  
PROTECT YES (Initial setting) ↔ PROTECT NO

### Notes

- If YES is selected, the adjusted contents are protected and stored into the preset buttons. When you want to store the parameter into a protected preset button, "Replace NO/YES" can be selected.
- If NO is selected, the preset is stored.
- While performing this operation, all adjusted contents of Parametric EQ/Graphic EQ and T.Correction will be stored in the preset buttons.
- The stored contents are not deleted even when resetting the unit or disconnecting the battery.
- The stored contents can be recalled by performing operation (refer to "Recalling the Stored Sound Field Adjustment Settings" on page 18).

## Recalling the Stored Sound Field Adjustment Settings

The stored Sound Field Settings contain Parametric EQ/Graphic EQ and T.Correction settings that are stored in the preset memory.

- 1 After selecting any item of the Sound Field mode (e.g. Parametric EQ), press any one of the **preset buttons (1 through 6)** that has your desired characteristic in memory to recall the stored settings.
- 2 Press the **preset buttons (1 through 6)** again to return to the Sound Field mode.

### Note

- While performing this operation, all adjustment contents of Parametric EQ/Graphic EQ and T.Correction stored in the preset buttons will be recalled.

## Other Functions

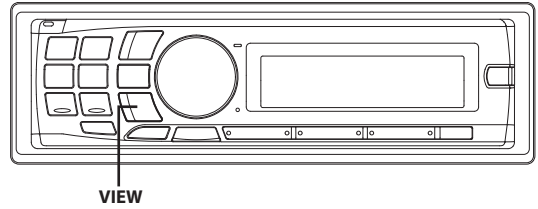

## Displaying the Text

Text information, such as the disc name and the track name, will be displayed if playing a CD text compatible disc. It is also possible to display the folder name, the file name and the tag, etc. while playing MP3/WMA/AAC files.

- 1 Press **VIEW**.

The display will change every time the button is pressed.

### Note

- When the Text Scroll is set to Manual, press and hold **VIEW** for at least 2 seconds, the current text will be scrolled one time (except Radio mode).

### The display in Radio mode:

If there is PS (Program Service Name)

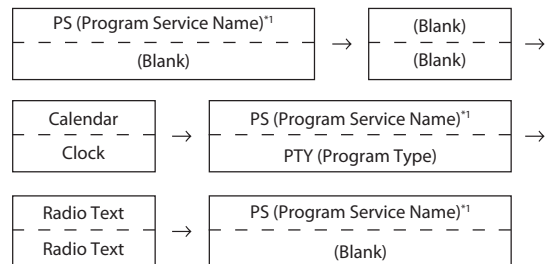

If there is no PS (Program Service Name)

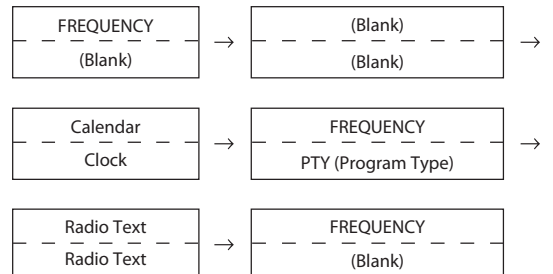

**The display in HD Radio mode:**

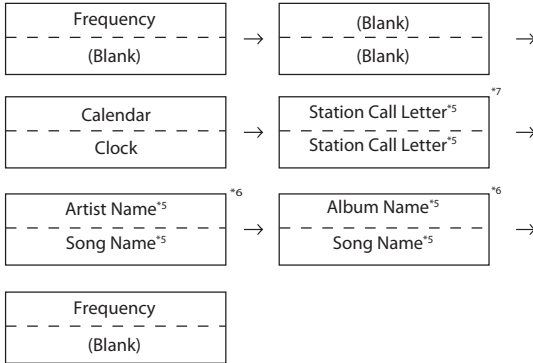

**The display in CD mode:**

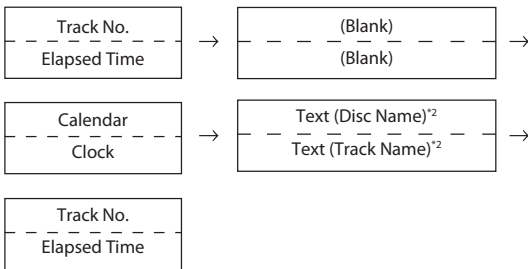

**The display in MP3/WMA/AAC mode:**

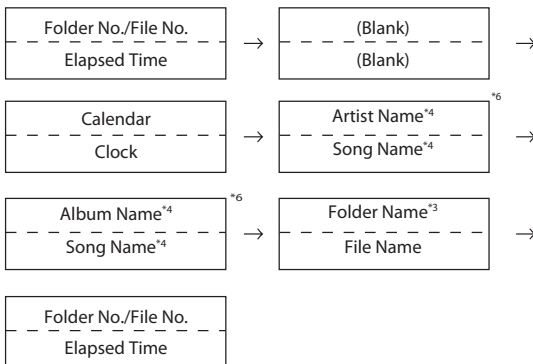

- \*1 Press and hold **VIEW** for at least 2 seconds if PS is displayed in the radio mode, frequency will be displayed for 5 seconds. If there is no text information, nothing will be displayed.
- \*2 Displayed during playback of a disc with CD Text. If there is no text information, nothing will be displayed.
- \*3 The root folder of disc/USB Memory is displayed as "\ROOT". If there is no text information, nothing will be displayed.
- \*4 If an MP3/WMA/AAC file contains ID3 tag/WMA tag information, the ID3 tag/WMA tag information is displayed (e.g., song name, artist name, and album name). All other tag data is ignored. If there is no text information, nothing will be displayed.
- \*5 When an HD Radio signal is received, text information such as Radio Station, Artist, etc., is displayed. If there is no text information, nothing will be displayed.

- \*6 When the Text Scroll (refer to "Scroll Setting (Text Scroll)" on page 23) is set to "Auto", the display cannot be switched by pressing **VIEW**. The display contents switch alternately.
- \*7 RADIO STATION NAME can be switched between "Long" and "Short", refer to "HD Radio Station Call Setting" on page 25. Displayed in 1 line when "Short" is set, displayed in 2 lines when "Long" is set.

**About the indication display**

When displaying Text, the following indicators are lit according to the mode.

Indicator/ Mode	CD Mode	MP3/ WMA/ AAC Mode	SAT RADIO/ HD Radio Mode	iPod Mode
	—	Folder Name being displayed	—	—
	—	Artist Name being displayed	Artist Name being displayed	Artist Name being displayed
	—	Album Name being displayed	Album Name being displayed (HD Radio mode only)	Album Name being displayed
	—	File Name being displayed	—	—
	Text (Disc Name) being displayed	—	—	—
	Text (Track Name) being displayed	Song Name being displayed	Song Name being displayed	Song Name being displayed
	—	—	Auxiliary Data Field being displayed (XM Radio only)	—
	—	—	Channel NO./Channel Name being displayed (XM/SIRIUS only)	—
	—	—	Category Name being displayed (XM/SIRIUS only)	—
	—	—	ID NO. (XM Radio only)	—

Indicator/ Mode	CD Mode	MP3/ WMA/ AAC Mode	SAT RADIO/ HD Radio Mode	iPod Mode
	—	—	Composer Name being displayed (SIRIUS Radio only)	—
	—	—	Station Call Letter being displayed (HD Radio mode only)	—
	—	—	SPS being displayed (HD Radio mode only)	—

## About “Text”

Text compatible CDs contain text information such as the disc name and track name. Such text information is referred to as “text”.

### Notes

- Some characters may not be displayed correctly with this device, depending on the character type.
- The CD changer must also be CD Text compatible for the Text information to be displayed.
- If there is no TEXT information, the display is blank.
- The text or tag information may not be correctly displayed, depending on the contents.

## Displaying Time

- 1 Press **VIEW** repeatedly until the time is displayed.

Each press changes the display.

For details, refer to “Displaying the Text” on page 18.

### Note

- Selecting any tuner or CD function while in the clock priority mode will interrupt the time display momentarily. The function selected will be displayed for about 5 seconds before the time returns to the display.

# SETUP

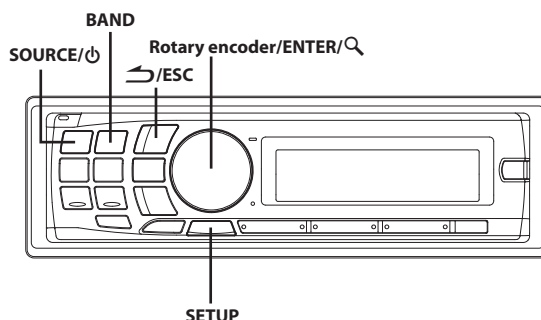

## Setting

You can flexibly customize the unit to suit your own preferences and usage. From the **SETUP** menu, General Setting, Display Setting, etc., can be modified.

**Use steps 1 to 5 to select one of the **SETUP** modes to modify. See the applicable section below for details about the selected **SETUP** item.**

- 1 Press and hold **SETUP** for at least 2 seconds to activate the **SETUP** mode.
- 2 Turn the **Rotary encoder** to select the desired item, and then press **ENTER/Q**.  
Bluetooth\*1 ↔ General ↔ Display ↔ Tuner\*2/HD Radio\*3 ↔ XM\*4/SIRIUS\*5 ↔ Bluetooth  
(e.g. Select General)
- 3 Turn the **Rotary encoder** to select a setting item, and then press **ENTER/Q**.  
(e.g. Select Power IC)

### Bluetooth:

Bluetooth IN

### General:

Birthday Set ↔ Clock Mode ↔ Clock Adjust\*6 ↔ Calendar ↔ Play Mode ↔ Beep ↔ INT Mute\*7 ↔ AUX+ Setup ↔ AUX+ Name\*8 ↔ AUX IN GAIN\*8 ↔ Digital AUX ↔ D.AUX Name\*9 ↔ AUX IN ↔ AUX Name\*10 ↔ Changer Name ↔ Power IC ↔ Language Set ↔ Demo ↔ Birthday Set

### Display:

Dimmer ↔ Dimmer Level ↔ Scroll Type ↔ Text Scroll ↔ Font Select ↔ BGV Select ↔ Opening MSG ↔ Dimmer

### Tuner:

Auto Clock\*11 ↔ FM Tuner Set ↔ Auto Clock

### XM:

XM ADF

### SIRIUS:

Clear Lock ↔ Clear Skip ↔ Sports ↔ S-Seek ↔ Clear Lock

### HD Radio:

Station Call ↔ Digital Seek ↔ Station Call

\*1 Displayed only when INT Mute is OFF and the mode is set to other than BLUETOOTH Audio.

\*2 Not displayed when HD Radio Tuner module is connected.

\*3 Only when HD Radio Tuner module is connected.

- \*4 Only when XM Radio is connected. For the XM Radio setting, refer to "SAT Radio Receiver (optional)" on page 26.
- \*5 Only when SIRIUS Radio is connected.
- \*6 Refer to "Setting the Time and Calendar" on page 8.
- \*7 Displayed only when Bluetooth IN is OFF.
- \*8 Displayed only when AUX+ Setup is ON.
- \*9 Displayed only when Digital AUX is ON.
- \*10 Displayed only when AUX IN is ON.
- \*11 Refer to "Setting the Time to automatically Adjust" on page 10.

**4 Turn the Rotary encoder to change the setting, and then press ENTER/Q.**  
(e.g. Select Power IC ON or Power IC OFF)

**5 Press and hold SETUP for at least 2 seconds to return to normal mode.**

#### Notes

- Pressing /ESC returns to the previous SETUP mode.
- If no operation is performed for 60 seconds, SETUP is canceled.

## BLUETOOTH Setting

Select Bluetooth from the setup main menu in step 2 above.

### Setting the BLUETOOTH Connection

If an optional BLUETOOTH INTERFACE (KCE-400BT) is connected, you can place a hands-free call by a BLUETOOTH-equipped mobile phone. Make this setting when the BLUETOOTH INTERFACE (KCE-400BT) is connected and the BLUETOOTH function is used. For details, refer to the Owner's Manual of the optional BLUETOOTH INTERFACE (KCE-400BT). Set ADAPTER when the BLUETOOTH INTERFACE (KCE-400BT) is connected.

#### Setting item: Bluetooth IN

**Setting contents:**  
ADAPTER / OFF (Initial setting)

#### Notes

- The  button can be used only when the optional BLUETOOTH INTERFACE (KCE-400BT) is connected.
- If the mobile phone compatible with the Voice Dial function is connected, the Voice Dial function can be used.
- When INT Mute is set to ON, the BLUETOOTH setting cannot be made. When the BLUETOOTH INTERFACE (KCE-400BT) is connected, set INT Mute to OFF. Refer to "Turning Mute Mode On/Off (INT Mute)" on page 22.

## General Setting

General is selected on the setup main menu in step 2.

### Birthday Opening Message Setting (Birthday Set)

While Opening MSG is set to ON (refer to "Opening Message ON/OFF Setting" on page 24), and then input your birthday details, a message can be displayed on that day. Turn the **Rotary encoder** to set "mm" (Month), and then press **ENTER/Q**. Turn the **Rotary encoder** again to set "dd" (Date).

#### Setting item: Birthday Set

**Setting contents:**  
mm/dd

### Setting the Clock Display (Clock Mode)

You can select the clock display type, 12-hour or 24-hour, depending on your preference.

#### Setting item: Clock Mode

**Setting contents:**  
AM (Before noon) 12:00 (12-hour) (Initial setting) / 00:00 (24-hour)

### Setting of Calendar Display Pattern Switching (Calendar)

You can switch the calendar display pattern to be shown when the time is displayed.

#### Setting item: Calendar

**Setting contents:**  
dd/mm/yyyy / yyyy/mm/dd / mm/dd/yyyy (Initial setting)

**yyyy :**  
Shows the year

**mm :**  
Shows the month

**dd :**  
Shows the day

ex. dd/mm/yyyy → 01/11/2009

### Playing MP3/WMA/AAC Data (Play Mode)

This unit can play back CDs containing both CD and MP3/WMA/AAC data (created in Enhanced CD (CD Extra) format). However, in some situations, playback of an enhanced CD may be difficult. In this case, you can select playback of a single session only, containing the CD data. When a disc contains both CD and MP3/WMA/AAC data, playback starts from the CD data portion of the disc.

#### Setting item: Play Mode

**Setting contents:**  
CD-DA (Initial setting) / CDDA&MP3/WMA

**CD-DA:**  
Only the CD data in Session 1 can be played back.

**CDDA&MP3/WMA:**  
CD data, MP3/WMA/AAC files in mixed mode, and multi-session discs can be played back.

#### Note

- Perform this setting before inserting a disc. If a disc has already been inserted, remove it first. (If you use an MP3 changer, you have to change discs.)

### Sound (Beep) Guide Function

This function will give audible feedback with varying tones depending upon the button pressed.

#### Setting item: Beep

**Setting contents:**  
ON (Initial setting) / OFF

## Turning Mute Mode On/Off (INT Mute)

If a device having the interrupt feature is connected, audio will be automatically muted whenever the interrupt signal is received from the device.

■ **Setting item:** INT Mute

**Setting contents:**

ON / OFF (Initial setting)

## Setting the AUX+ Setup Mode

You can input the audio of an external device, (such as a Portable audio player) to the BLUETOOTH interface connector of this unit. A special Conversion cable (KCE-237B) is necessary to adapt the BLUETOOTH interface connector as an AUX IN.

A portable music device and a BLUETOOTH INTERFACE (KCE-400BT) cannot be connected to the BLUETOOTH interface connector at the same time.

■ **Setting item:** AUX+ Setup

**Setting contents:**

ON / OFF (Initial setting)

**ON\*:**

Set to ON when a portable device is connected. If SOURCE/⏻ is pressed and AUX+ is selected, the sound of the portable device is input to the unit.

\* You can change the AUX+ Name display when AUX+ Setup is set to ON. Press ENTER/⏻ when AUX+ SETUP is set to ON, and select AUX+ Name by turning the Rotary encoder, then press ENTER/⏻. After that, turn the Rotary encoder to select the desired AUX+ Name.

**OFF:**

When set to OFF, AUX+ source cannot be selected.

## Setting the AUX+ Level (AUX IN GAIN)

After setting to ON in "Setting the AUX+ Setup Mode", this setting can be carried out.

■ **Setting item:** AUX IN GAIN

**Setting contents:**

Low (Initial setting) / High

**Low:**

Decreases the external input audio level.

**High:**

Increases the external input audio level.

## Setting the External Digital Input

When an ALPINE Ai-NET compatible digital audio processor (PXA-H701) and a DVD player (DVE-5207) not compatible with Ai-NET are connected, set Digital AUX to ON to enjoy 5.1-channel surround sound.

You can change the Digital AUX name display when Digital AUX is set to ON. Press ENTER/⏻ when Digital AUX is set to ON, and select Digital AUX name by turning the Rotary encoder, then press ENTER/⏻. After that, turn the Rotary encoder to select the desired Digital AUX name.

■ **Setting item:** Digital AUX

**Setting contents:**

ON / OFF (Initial setting)

**Notes**

- Press SOURCE/⏻, and select the D.Aux mode, and adjust the volume, etc.
- After input selection is completed, turn the ignition off and back on again. Setting of the optical digital input switch is completed.

- Depending on the connected audio processor, DVD player sound may continue to be output, even though the source is changed to another one. If this occurs, set the DVD player's power to OFF.

## Setting the AUX Mode (V-Link)

You can input TV/video sound by connecting an optional Ai-NET/RCA Interface cable (KCA-121B) or Versatile Link Terminal (KCA-410C) to this component.

You can change the AUX name display when AUX IN is set to ON. Press ENTER/⏻ when AUX IN is set to ON, and select AUX Name by turning the Rotary encoder, and then press ENTER/⏻.

After that, turn the Rotary encoder to select the desired AUX name. If the KCA-410C is connected, it is possible to select two AUX names.

■ **Setting item:** AUX IN

**Setting contents:**

ON / OFF (Initial setting)

**Note**

- Via KCA-410C, up to 2 external devices with RCA output can be connected. In this case, press SOURCE/⏻ to select AUX mode and then press BAND to select your desired device.

## Changer Name Setting

This setting is used when the head unit is connected to the USB Adapter for MP3 (KCA-620M). You can set the name to be displayed on the unit depending on the device to which the USB Adapter for MP3 (KCA-620M) is connected.

■ **Setting item:** Changer Name

**Setting contents:**

Changer (Initial setting) / USB / Portable

## Connecting to an External Amplifier

When an external amplifier is connected, sound quality can be improved by stopping the power supply of the built-in amplifier.

■ **Setting item:** Power IC

**Setting contents:**

ON (Initial setting) / OFF

**Power IC ON:**

The speakers are driven by the built-in amplifier.

**Power IC OFF:**

Use this mode when the line output of this unit is used to drive an external amplifier. In this setting, the head unit's internal amplifier is turned OFF and can not drive speakers.

**POWER IC ON:**

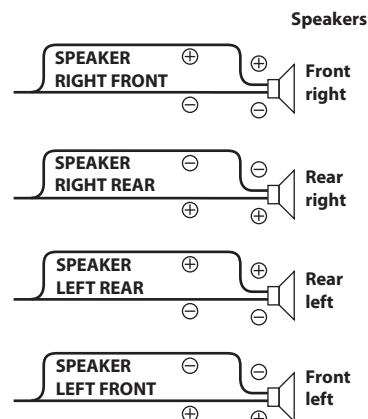



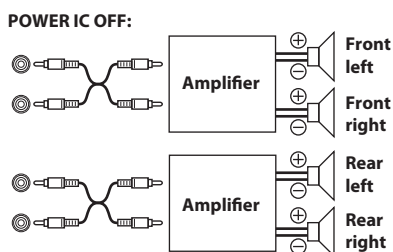

**Note**

- No sound is produced by the system when the Power IC is set to OFF.

## Setting the Language Font

Two types of font can be selected.

**Setting item:** Language Set

**Setting contents:**

Language 1 (Initial setting) / Language 2

**Language 1 :**

Normal Font

**Language 2 :**

European Font

## Demonstration

This unit has a demonstration feature for the display.

**Setting item:** Demo

**Setting contents:**

ON / OFF (Initial setting)

**Note**

- To quit Demo mode, set to Demo OFF.

## Display Setting

Display is selected on the setup main menu in step 2.

## Dimmer Control

Set the Dimmer control to Auto to decrease the illumination brightness of the unit with the head lights of the vehicle ON. This mode is useful if you feel the unit's backlighting is too bright at night.

**Setting item:** Dimmer

**Setting contents:**

Auto (Initial setting) / Manual

## Dimmer Level Setting

In the Dimmer Level setting, three levels are available, the highest level (Lev3) being the dimmest when the car headlights are on.

**Setting item:** Dimmer Level

**Setting contents:**

Lev1 (Initial setting) / Lev2 / Lev3

## Scroll Type Setting

Choose from two scrolling methods.

Select the type you prefer.

**Setting item:** Scroll Type

**Setting contents:**

TYPE 1 / TYPE 2 (Initial setting)

**TYPE 1 :**

The characters scroll from right to left, one character at a time, until the entire title has scrolled.

**TYPE 2 :**

Words are built up from left to right, a single character at a time. When the display is full, it is cleared and the subsequent words are displayed the same way until all words of the title have been shown.

## Scroll Setting (Text Scroll)

This CD player can scroll the disc and track names recorded on CD-TEXT discs, as well as text information of MP3/WMA/AAC files, folder names, tags, HD Radio broadcasts and SAT Radio.

**Setting item:** Text Scroll

**Setting contents:**

Auto / Manual (Initial setting)

**Text Scroll Auto:**

CD text information, folder and file names, HD Radio and SAT Radio text are scrolled continuously. In addition, all tag information is automatically rotated in the display continuously, without pressing the VIEW button. (except SAT Radio)

**Text Scroll Manual:**

The above information is scrolled only when a disc is loaded, a channel or track is changed, etc.

**Note**

- In parts of the display, scrolling may not occur, or scroll content may differ.

## Switching the Character Font

Two types of font can be selected.

You can select the font type you like.

**Setting item:** Font Select

**Setting contents:**

TYPE 1 (Initial setting) / TYPE 2

## Switching the Animation Display Type (BGV Select)

You can select your favorite animation display for background from 4 types.

**Setting item:** BGV Select

**Setting contents:**

OFF (Initial setting) / TYPE 1 / TYPE 2 / TYPE 3 / TYPE 4

## Opening Message ON/OFF Setting

This unit includes a special message feature with various patterns, which when enabled displays opening messages for certain occasions. For example, when you turn this unit on December 25th (according to the unit's date setting), a Christmas greeting is displayed if the Opening Message is set to ON.

■ **Setting item:** Opening MSG

**Setting contents:**  
ON / OFF (Initial setting)

## Tuner Setting

Tuner is selected on the setup main menu in step 2.

## Setting the TUNER (FM) tone quality

This unit can set your preferred tone quality for FM radio source.

■ **Setting item:** FM Tuner Set

**Setting contents:**  
Normal (Initial setting) / HiFi / Stable

**Normal:**  
Standard setting

**HiFi:**  
High-quality setting

**Stable:**  
Control noise

### Note

- Noise may be more noticeable when HiFi is set, depending on the reception status. In this case, the Normal setting is recommended.

## SIRIUS Radio Setting (Only when a SIRIUS Receiver Box is connected)

SIRIUS is selected on the setup main menu in step 2.

## Unlock the Locked Channels

The connected optional SIRIUS Receiver Box may have the ability to lock out channels with password protection. The locked channels can not be accessed with this unit. However, the following operation will clear the lock to receive these channels as normal.

■ **Setting item:** Clear Lock

**Setting contents:**  
Yes / No

**Yes:**  
Unlock the locked channels.

**No:**  
Keep the lock state.

### Notes

- You cannot set a channel as lock channel from this unit. Please operate from the SIRIUS Receiver Box. For details, refer to the owner's manual of the optional SIRIUS Receiver Box.
- Depending on the connected SIRIUS Interface, this setting item may not be displayed.

## Clearing the Setting of Skipped Channels

The optional SIRIUS Receiver Box may have the ability to create an undesired channel list. Using the channel UP/DOWN operation skips the channels in this list automatically. The following operation will prevent the skipping of the listed channels.

■ **Setting item:** Clear Skip

**Setting contents:**  
Yes / No

**Yes:**  
Clear the setting of skipped channels.

**No:**  
Keep the skip state.

### Notes

- You cannot set a channel as skipped channel from this unit. Please operate from the SIRIUS Receiver Box. For details, refer to the owner's manual of the optional SIRIUS Receiver Box.
- Depending on the connected SIRIUS Interface, this setting item may not be displayed.

## Setting the Favorite Sports Team announcement

The following operation sets the announcement for your favorite sports team.

■ **Setting item:** Sports

**Setting contents:**  
Favorite Teams / Game Alert

### Favorite Teams

After access to this item, a sports league list will be displayed.

- 1 Turn the **Rotary encoder** to select the desired league, and then press **ENTER/Q**.
- 2 Turn the **Rotary encoder** to select a team you want to store, and then press **ENTER/Q**.  
The screen will ask which kind of alert you wish to have.

### Note

- Select "None" on the list if you do not want to store in memory. No alert interruption will occur.

- 3 Turn the **Rotary encoder** to select the desired alert type, and then press **ENTER/Q**.  
Initial Game Alert/All Score Updates (Initial setting)

### Initial Game Alert:

The alert display interrupts when the game begins.

### All Score Updates:

The alert display interrupts by game progress (change of score, game result, etc.).

### Game Alert

After access to this item, operate the unit as follow.

- 1 Turn the **Rotary encoder** to set Game Alert to On or Off, and then press **ENTER/Q**.  
If On is set, the alert for all stored sports teams is set.  
If Off is set, no announcements will be made.

## Setting the Sirius Seek (S-Seek) Alert

The following operations can be performed to change the Sirius Seek Alert settings.

■ **Setting item:** S-Seek

**Setting contents:**  
S-Seek Alert / Delete All / Memory Recall

### S-Seek Alert

This feature allows you to capture information in the Receiver's memory about the currently tuned programming—artist or song. When S-Seek Alert is ON, the Receiver then continuously searches all incoming SIRIUS channels and alerts the user when a program saved in memory matches a selection currently being played. After access to this item, operate the unit as follow.

- 1 Turn the **Rotary encoder** to set S-Seek Alert to On or Off, and then press **ENTER/Q**.

If On is set, the alert for all stored Artists/Songs is set.  
If Off is set, no announcements will be made.

#### Delete All

The operation will delete all alerts (artists, songs and team) stored in memory.

After access to this item, operate the unit as follow.

- 1 Turn the **Rotary encoder** to select Yes, and then press **ENTER/Q**.

#### Memory Recall

You can manage the stored Alert (Artist, Songs, Sports team) individually by this setting.

After access to this item, the alert memory select screen will be displayed.

#### Display example for alert memory select screen



- ① Display the alert state. (✓ : The alert is ON; ✕ : The alert is OFF)
- ② Display the sequence number of stored alert item and the total items can be stored.
- ③ Display the type of the stored memory recall.  
 🎤 : Artist Memory Recall  
 🎵 : Song Memory Recall  
 🏆 : Sports team Memory Recall.
- ④ Display the artist, song or team name.

- 1 Turn the **Rotary encoder** to select the desired alert item, and then press **ENTER/Q**.

The manage list for the selected alert is displayed. You can set the alert to on, off or delete the alert. You can select the alert type if the managed alert is a song alert or a game alert.

- 2 Turn the **Rotary encoder** to select the desired setting, and then press **ENTER/Q**.

If the selected alert is Artist alert, you can manage the alert as following:

Artist Seek On<sup>\*1</sup> ↔ Artist Seek Off<sup>\*2</sup> ↔ Delete<sup>\*3</sup>

\*1 Set the stored Artist alert to on.

\*2 Set the stored Artist alert to off.

\*3 Delete the stored Artist alert.

If the selected alert is Song alert, you can manage the alert as following:

Song Seek On<sup>\*1</sup> ↔ Song Seek Off<sup>\*2</sup> ↔ Seek Artist Only<sup>\*3</sup>  
 ↔ Delete<sup>\*4</sup>

\*1 Set the stored Song alert to on.

\*2 Set the stored Song alert to off.

\*3 Only set the stored Song's artist alert to on

\*4 Delete the stored Song alert.

If the selected alert is Game alert, you can manage the alert as following:

Initial Game Alert<sup>\*1</sup> ↔ All Score Updates<sup>\*2</sup> ↔ Off<sup>\*3</sup> ↔  
 Delete<sup>\*4</sup>

\*1 The alert display interrupts when the game begins.

\*2 The alert display interrupts by game progress (change of score, game result, etc.).

\*3 Set the stored Game alert to off.

\*4 Delete the stored Game alert.

#### Notes

- If you want to delete a alert memory in the above procedure, a delete confirmation screen will appear, turn the **Rotary encoder** to select "Yes", and then press **ENTER/Q**.
- Depending on the connected SIRIUS Interface, some setting items and display indications do not work.

## HD Radio Reception (only when HD Radio Tuner module is connected)

HD Radio mode is selected on the setup main menu in step 2.

### HD Radio Station Call Setting

In the HD Radio mode, the number of display characters for the HD Radio station name can be selected.

#### Setting item: Station Call

##### Setting contents:

Short (Initial setting) / Long

##### Short :

7 characters (FM)

4 characters (AM)

##### Long :

56 characters

### Digital Seek ON/OFF Setting

#### Setting item: Digital Seek

##### Setting contents:

ON / OFF (Initial setting)

##### ON :

SEEK UP/DOWN is used only for Digital Radio Station.

##### OFF :

SEEK UP/DOWN is used for all Radio Stations.

# SAT Radio Receiver (optional)

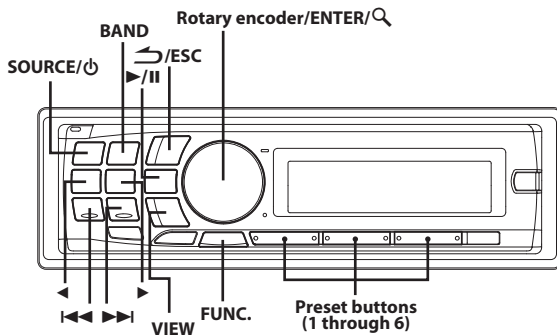

## SAT Receiver:

XM or SIRIUS Receiver\*

When an optional XM or SIRIUS Receiver Box is connected via the Ai-NET bus, the following operations may be performed. However, the XM Receiver and SIRIUS Receiver cannot be connected at the same time.

\* Verify the features of the connected SIRIUS Receiver Box. Not all SIRIUS Receivers have identical functions and some may not be performed on this unit. For details about functions, refer to the SIRIUS Receiver's Owner's Manual.

## Receiving Channels with the SAT Radio Receiver (optional)

### About SAT Radio

Satellite Radio\*<sup>1-2</sup> is the next generation of audio entertainment, with over 100 digital audio channels. For a small monthly fee, subscribers can hear crystal-clear music, sports, news and talk, coast-to-coast via satellite. For more information, visit XM's website at [www.xmradio.com](http://www.xmradio.com), or SIRIUS' website at [www.sirius.com](http://www.sirius.com).

\*1 XM and its corresponding logos are trademarks of XM Satellite Radio Inc.

\*2 SIRIUS and its corresponding logos are trademarks of SIRIUS Satellite Radio Inc.

To receive SAT Radio, the separately sold XM Direct™ or SIRIUS Satellite Radio Tuner and an appropriate Ai-NET Interface Adapter will be required. For details, consult your nearest Alpine dealer.

### Note

- The SAT Receiver controls on this unit are operative only when a SAT Receiver is connected.

- Press **SOURCE/⏻** to activate the SAT Radio mode.
- Press **BAND** to select one of the three SAT Radio Preset Bands.

Each press changes the band:

#### XM mode:

XM1 → XM2 → XM3 → XM1

#### SIRIUS mode:

SIRIUS1 → SIRIUS2 → SIRIUS3 → SIRIUS1

- Press **◀** or **▶** to select desired category.

- Press **◀◀** or **▶▶** to select the desired channel.  
Holding down **◀◀** or **▶▶** will change channels continuously.
- While in XM or SIRIUS Radio mode, enter the Channel number you want to call up with the numeric keypad on the remote control.
- Press **Enter** on the remote control within 5 seconds to receive the Channel.

### Note

- When using the optional remote control (RUE-4190, etc.), an SAT Radio Channel can be directly called up with the numeric keypad of the remote control.

## Checking the SAT Radio ID Number

A unique SAT Radio ID number is required to subscribe to SAT Radio programming. Each third party XM or SIRIUS radio comes with this number.

This number is an 8 character (for XM Radio) or 12 character (for SIRIUS Radio) alphanumeric number. It is printed on a label found on the SAT Receiver.

It can also be displayed on the screen of this unit in the following way.

### XM mode:

- While receiving a SAT Radio band, press **◀◀** or **▶▶** to select channel "0" for XM.

The unit displays "RADIO ID" and ID number simultaneously. While displaying "RADIO ID" as shown above, Demonstration become nonfunctional (refer to "Demonstration" on page 23).

- To cancel the ID number display, select the channel other than "0".

### SIRIUS mode:

- While receiving a SAT Radio band, press **◀◀** or **▶▶** to select channel "255" or "0" for SIRIUS.

- Press **VIEW** until the ID No. appears in the display.

The SIRIUS ID is displayed when the Song Name display mode is toggled. For details, refer to "Changing the Display" on page 29.

- To cancel the ID number display, set the channel to other than "255" and "0".

### Note

- You can check the ID number printed on a label on your third party, SAT Radio Receiver package.

## Storing Channel Presets

- Press **BAND** to select the desired band you want to store.
- After tuning in the desired channel, press and hold, for at least 2 seconds, any one of the preset buttons (1 through 6) into which you wish to store the channel.  
The selected channel is stored.
- Repeat the procedure to store up to 5 other channels onto the same band.

### Notes

- To use this procedure for other bands, simply select the band desired and repeat the procedure.

- A total of 18 channels can be stored in the preset memory for either XM or SIRIUS. 6 Channels are stored in each band (XM1, XM2 and XM3 for XM; SIRIUS1, SIRIUS2 and SIRIUS3 for SIRIUS).
- If you store a channel in a preset memory which already has a station, the current channel will be cleared and replaced with the new one.

## Receiving Stored Channels

- 1 Press **BAND** to select the desired band.
- 2 Press the channel preset button (1 through 6) that has your desired satellite channel in memory.

## Storing the desired Sports Team (SIRIUS only)

Store a favorite team from one of the available leagues SIRIUS covers. Once stored, game times and scores for that team are announced using the interruption ALERT display while receiving other programming. To receive these announcements, refer to “Activating the stored Alert (SIRIUS only)” on page 27.

This function becomes effective after performing the following operation and set Game Alert to ON. On how to set Game Alert to On, refer to “Setting the Favorite Sports Team announcement” on page 24.

### Storing while receiving a game broadcast

- 1 Press **FUNC.** when a team's game you want to store is being broadcast.  
A note to memory which sports team is displayed.  
**Note**
  - If either of the teams is not available to save, that team will be displayed as unavailable.
- 2 Turn the **Rotary encoder** to select the desired team (when available) for the game being broadcast, and then press **ENTER/Q**.
- 3 Turn the **Rotary encoder** to select interruption type, and then press **ENTER/Q**.  
Initial Game Alert/All Score Updates (Initial setting)  
**Initial Game Alert:**  
The ALERT display interrupts when the game begins.  
**All Score Updates:**  
The ALERT display interrupts by game progress (change of score, game result, etc.).
- 4 The new alert was stored in memory.

A “Game Stored” pop-up screen followed by an “X Used/Y Empty”.  
X is the total number of listings stored in memory, and Y is the total number of memory listings still available for storage.

#### Notes

- If you try to store when the memory area is full, “Memory Full” is displayed for 2 seconds. Following that display, the existing alert list stored in memory is displayed. Select one of the stored alerts using the **Rotary encoder**. To replace the selected alert, press **ENTER/Q** and a “Replace” or “Cancel” screen will then be displayed. Select “Replace” by turning the **Rotary encoder**, and then press **ENTER/Q**.
- You can manage the stored Alert memory setting on Setup mode, for details, refer to “Setting the Sirius Seek (S-Seek) Alert” on page 24.
- You can also store the desired sports teams on Setup mode, for details, refer to “Setting the Favorite Sports Team announcement” on page 24.

- If no operation is performed for 10 seconds, the setting mode is canceled.

## Storing the desired Artist/Song (SIRIUS only)

A stored artist name or song title is announced whenever a matching artist or title is found on another channel. The interruption ALERT is displayed while listening to a program on another channel. For receiving interruption information, refer to “Activating the stored Alert (SIRIUS only)” on page 27.

- 1 Press **FUNC.** when a Song or the song of an Artist you want to store is being broadcast.

A note to memorize the artist (name) or the song (title) is displayed.

#### Note

- If either the artist name or song title is not available to save, the choice will be displayed as unavailable.

- 2 Turn the **Rotary encoder** to choose Store Artist or Store Song (when available) and press **ENTER/Q**.

- 3 The new alert was stored in memory.

A “Artist/Song Stored” pop-up screen followed by an “X Used/Y Empty”.

X is the total number of listings stored in memory, and Y is the total number of memory listings still available for storage.

#### Notes

- If you try to store when the memory area is full, “Memory Full” is displayed for 2 seconds. Following that display, the existing alert list stored in memory is displayed. Select one of the stored alerts using the **Rotary encoder**. To replace the selected alert, press **ENTER/Q** and a “Replace” or “Cancel” screen will then be displayed. Select “Replace” by turning the **Rotary encoder**, and then press **ENTER/Q**.
- You can manage the stored Alert memory setting on Setup mode, for details, refer to “Setting the Sirius Seek (S-Seek) Alert” on page 24.
- If no operation is performed for 10 seconds, the setting mode is canceled.

## Activating the stored Alert (SIRIUS only)

Make sure that Game Alert (Refer to “Setting the Favorite Sports Team announcement” on page 24)/S-Seek Alert (Refer to “Setting the Sirius Seek (S-Seek) Alert” on page 24) is set to ON. When the Game Alert/S-Seek option is enabled. Whenever the stored sports team, artist(s) or song(s) are playing, an interruption ALERT appears in the display of the unit.

The interruption (A) ALERT indicator is either on or blinking depending on the conditions listed below.

(A) (ALERT) indicator lights	one Alert found.
(A) (ALERT) indicator blinks	more than 2 Alerts found.

If more than 2 Alerts are found (Blinking ALERT indicator):

- 1 Turn the **Rotary encoder** to select the desired information.

#### Note

- You can toggle the display between the artist name list and the song/program title list or toggle the game information by pressing **VIEW** in this step.

- 2 Press **ENTER/Q**.

#### Notes

- If no operation is performed for 10 seconds, the unit returns to normal mode.

- Sports teams/Artist name and Song title which you have stored and which are currently playing will be displayed in a category called “My Game Zone”/“S-Seek” in search mode. For details, refer to “Search Function” on page 28.

## Search Function

You can search for programs by Category, Channel.

### Category Search mode

- 1 Press **ENTER/Q** in the XM or SIRIUS mode.
- 2 Turn the **Rotary encoder** to select Category search mode, and then press **ENTER/Q**.  
Category ↔ Channel ↔ S-Seek\* ↔ My Game Zone\* ↔ Category  
\* SIRIUS Only. Displayed only when (A) appears. For details, refer to “Activating the stored Alert (SIRIUS only)” on page 27.
- 3 Turn the **Rotary encoder** to select the desired Category, and then press **ENTER/Q**.
- 4 Turn the **Rotary encoder** to select the desired Channel Name, and then press **ENTER/Q**.

#### Notes

- During channel search, pressing ◀ or ▶ to select another Category.
- While in Category Search mode, press ↵/ESC to return to the selecting search mode.
- The Search mode is canceled if you press and hold ↵/ESC for at least 2 seconds, or no operation is performed for 60 seconds in Category Search mode.
- During Channel search, You can toggle the display between the channel name list, artist name list and the song/program title list by pressing **VIEW** (SIRIUS only).

### Channel Search mode

- 1 Press **ENTER/Q** in the XM or SIRIUS mode.
  - 2 Turn the **Rotary encoder** to select Channel Search mode, and then press **ENTER/Q**.  
Category ↔ Channel ↔ S-Seek\* ↔ My Game Zone\* ↔ Category  
\* SIRIUS Only. Displayed only when (A) appears. For details, refer to “Activating the stored Alert (SIRIUS only)” on page 27.
- Note**
- During Channel search, pressing **VIEW** will toggle the display between the channel name list, artist name list and the song/program title list.
- 3 Turn the **Rotary encoder** to select the desired Channel, and then press **ENTER/Q**.

#### Notes

- When the (A) appears, the “S-Seek” or “My Game Zone” (which displays a list of the current matches) should be accessible via view search options. You can select the artist, song, or sports game that you wish to tune to by turning the **Rotary encoder** from the list, and then pressing **ENTER/Q**. During the searching, you can toggle the display between the artist name list and the song/program title list or toggle the display between the team names and the current score of any live play-by-play game by pressing **VIEW**.
- Press ↵/ESC in the search mode to return to the previous mode.
- The Search mode is canceled if you press and hold ↵/ESC for at least 2 seconds, or no operation is performed for 60 seconds.
- Depending on the connected SIRIUS Interface, some functions and display indications do not work.

## Quick Search Function

You can search for all channels in numerical order.

- 1 Press and hold **ENTER/Q** for at least 2 seconds in XM or SIRIUS mode to activate Quick Search mode.
- 2 Turn the **Rotary encoder** to select the desired Channel within 10 seconds.  
The selected Channel is received.

## Receiving Weather or Traffic Information from SAT Radio

- 1 Select the **SAT Radio Channel** for your local traffic/weather information.
- 2 Press and hold **▶/II** for at least 2 seconds in the SAT mode.  
The received weather or traffic channel is stored.
- 3 Press and hold **BAND** for at least 2 seconds.  
The stored Weather or Traffic channel will be recalled.
- 4 Press and hold **BAND** for at least 2 seconds.  
Returns to normal mode.

#### Notes

- Stored channels can also be recalled by pressing and holding **BAND** for at least 2 seconds.
- Channel other than Weather or Traffic can also be stored and recalled.

## Instant Replay Function (SIRIUS only)

In SIRIUS mode, the current channel is saved using the Instant Replay memory function. Use this function to pause the channel content at any time. When playback is continued, it will begin at the position it was paused.

- 1 During SIRIUS reception, press **▶/II** to place the Receiver in the Instant Replay pause mode, which mutes the audio.  
The “Instant Replay” is displayed.
- 2 Press **▶/II** again to have the Receiver resume playback of the stored audio from the point at which it was paused.  
During playback, the Receiver will continue to store the channel audio until you exit the Instant Replay mode.

#### During REPLAY playback:

- Fast rewind:  
Press and hold **◀◀**.
- Fast forward:  
Press and hold **▶▶**.
- Returning to the beginning of the current song:  
Press **◀◀**.
- Advancing to the beginning of the next song:  
Press **▶▶**.

#### Note

- If you continue to press Fast forward until the end, the Instant Replay mode is canceled, and the unit will change to usual reception.

### 3 Press **↵/ESC** for at least 2 seconds to cancel the INSTANT REPLAY mode.

The unit returns to usual SIRIUS broadcasting mode.  
Time display example during REPLAY playback (Instant Replay Mode only)

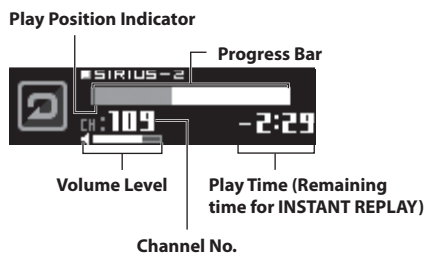

## Changing the Display

Text information, such as the channel name, artist name/feature and song/program title, is available with each XM or Sirius channel. The unit can display this text information as explained below.

### 1 In XM or SIRIUS mode, press **VIEW**.

Each time you press this button, the display changes as shown below.

#### XM mode:

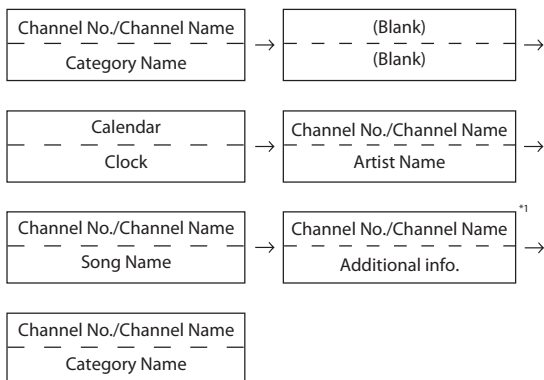

#### SIRIUS mode:

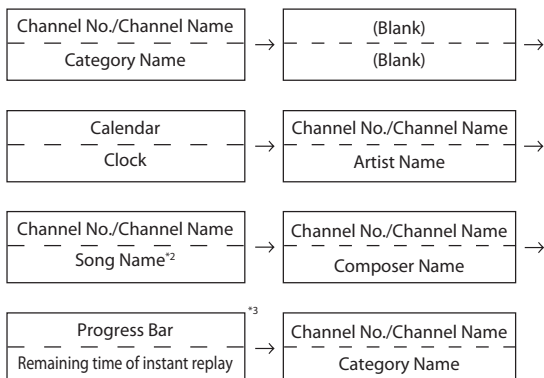

- \*1 When ADF is turned OFF, this information is not displayed (refer to "Setting the Auxiliary Data Field Display (XM only)" on page 29).  
Displayed in 1 line when text amount is small.
- \*2 When the channel "0" or "255" is selected, the SIRIUS ID number is displayed.
- \*3 Displayed only during instant replay.

#### Notes

- When the "Text Scroll" (Refer to "Scroll Setting (Text Scroll)" on page 23) is set to "Auto," the display scrolls continuously. When the "Text Scroll" is set to "Manual," the display scrolls only once after any function is performed (PRESET, BAND, SEARCH, etc.). "Channel No.," "Calendar" and "Clock" displays do not scroll.
- Depending on the model, the display may differ from the one shown above.

## Setting the Auxiliary Data Field Display (XM only)

The XM Auxiliary Data Field (ADF) display can be switched on or off. There is no ADF function for the SIRIUS receiver.

### 1 Press and hold **SETUP** for at least 2 seconds to activate the SETUP selection mode.

### 2 Turn the **Rotary encoder** to select the XM mode, and then press **ENTER/Q**.

Bluetooth<sup>\*1</sup> ↔ General ↔ Display ↔ Tuner<sup>\*2</sup>/HD Radio<sup>\*3</sup> ↔ XM<sup>\*4</sup>/SIRIUS<sup>\*5</sup> ↔ Bluetooth

- \*1 Displayed only when INT Mute is OFF and the mode is set to other than Bluetooth Audio.
- \*2 Not displayed when HD Radio Tuner module is connected.
- \*3 Only when HD Radio Tuner module is connected.
- \*4 Only when XM Radio is connected.
- \*5 Only when SIRIUS Radio is connected.

### 3 Press **ENTER/Q** to activate the XM ADF mode.

### 4 Turn the **Rotary encoder** to select XM ADF ON/OFF, and then press **ENTER/Q**.

When setting to ON, Auxiliary Data Field is displayed by pressing **VIEW** (refer to "Changing the Display" on page 29).

### 5 Press and hold **SETUP** for at least 2 seconds to return to normal mode.

#### Notes

- Pressing **↵/ESC** returns to the previous SETUP mode.
- If no operation is performed for 60 seconds, SETUP is canceled.

# USB Memory/Portable audio player (optional)

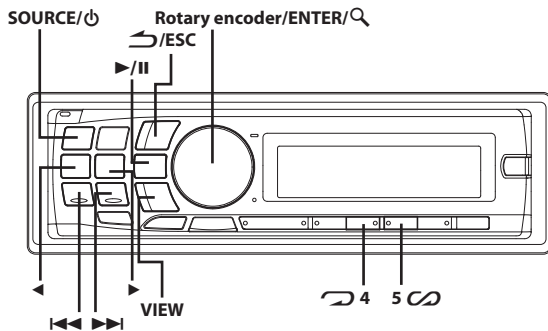

## Connecting the USB Memory (optional)

If a USB Memory device/Portable audio player is connected to the unit, MP3/WMA/AAC files can be played back.

### Note

- In the USB mode, when this unit is reset, ACC is switched from OFF to ON, or when the USB is connected to this unit, "Banking" is displayed for several seconds.

## Using the USB Memory/Portable audio player Banking Function

### What is a Bank?

A bank is a unit of up to 1,000 songs, which is stored in memory/Portable audio player. "Banking" refers to the grouping of songs available in USB Memory/Portable audio player, in banks of 1,000 songs each. However, when a USB Memory is connected, 1BANK can store up to 1,000 songs under the following conditions. Otherwise, the number of songs that can be stored may be less than 1,000. Conditions (general estimate values)

Playlists: 20 (32 characters; 64 bytes)  
 Genres: 10 (32 characters; 64 bytes)  
 Composers: 30 (32 characters; 64 bytes)  
 Artists: 30 (32 characters; 64 bytes)  
 Albums: 100 (32 characters; 64 bytes)  
 Titles: 1,000 (32 characters; 64 bytes)  
 Folders: 100 (32 characters; 64 bytes)  
 Files: 1,000 (32 characters; 64 bytes)  
 File Paths: 1,000 (128 characters; 256 bytes)

### About Banking

While a bank is being built up, "Banking" is displayed. Banking occurs whenever a USB Memory device/Portable audio player is connected or after power to the head unit turns on. It can take anywhere from a few seconds to up to several minutes for banking to complete. This depends on the number of files and folders in USB Memory/Portable audio player.

### Available operations while Banking

- During Banking, the information display changes so the VIEW operation is not available.
- With a song playing, Regular fast-forwarding and next song selection is available.
- While Banking, the song playback order may differ from the song order in the USB Memory device/Portable audio player.

- Searching is not recommended during the Banking process as the database is under construction at this time, and malfunction may result in some cases.

This unit has a BANK function that automatically divides every 1,000 songs stored in USB Memory/Portable audio player into individual banks to make searching and playing back a song easier. A maximum of 1,000 songs for one bank can be stored according to the order stored in USB Memory/Portable audio player. A maximum of 20 banks (20,000 songs) can be recognized.

Bank No.	Song number
Bank1	1~1,000
Bank2	1,001~2,000
⋮	⋮
Bank20	19,001~20,000

## Playback

- Press SOURCE/⏻ to select the USB mode.
- Press << or >> to select the desired track (file).  
Pressing and holding << or >> will fast backward/fast forward track continuously.

### Notes

- If a song is fast reversed to its beginning in pause mode, the song will be played back automatically.
- Depending on the connected portable audio player, fast-forwarding/fast-reversing may not be available.

- To pause playback, press >/II.

Pressing >/II again will resume playback.

### Notes

- WMA format files that are protected by DRM (Digital Rights Management), AAC format files that have been purchased from the iTunes Store and files that are copy-protected (copyright protection) cannot be played back on this unit.
- The playback time may not be correctly displayed when a VBR (Variable Bit Rate) recorded file is played back.
- If there is tag information, artist name/album name/track name is displayed.
- If an MP3/WMA/AAC file contains ID3 tag/WMA tag information, the ID3 tag/WMA tag information is displayed (e.g., song name, artist name, and album name). All other tag data is ignored.
- If text information is not compatible with this unit, the display is blank.
- Before disconnecting USB Memory, be sure to change to another source or set to pause.
- Press VIEW to switch the display. For details, refer to "Displaying the Text" on page 18.

## Repeat Play

- Press ↺ 4.

The song is played back repeatedly.

RPT<sup>1</sup> → RPT <sup>2</sup> → RPT <sup>3</sup> → (off) → RPT

\*1 Only a file is repeatedly played back.

\*2 According to the artist information of the current song, a playlist about all the songs with the same artist of the Bank are made into a playlist, which then starts to play back.

\*3 According to the album information of the current song, a playlist about all the songs with the same album of the Bank are made into a playlist, which then starts to play back.



**2** To cancel repeat play, select (off) with the above procedure.

**Note**

- During repeat play, setting M.I.X. to ON will cancel the repeat play.

## M.I.X. (Random Play)

**1** Press 5 .

The songs are played back in random sequence.

MIX\*1 → MIX ALL\*2 → (off) → MIX

\*1 Song shuffle randomly plays back songs within a selected category (playlist, album, etc.). The songs within the category are played just once until all songs have been played.

\*2 All songs in the current Bank are played back in random sequence. Any one song does not play back again until all songs have been played back.

**2** To cancel M.I.X. play, select (off) with the above procedure.

**Notes**

- When a song is played back during Random (M.I.X.) play in the USB mode, the song can be played back again randomly even if not all songs in the current Bank have been played back.
- During M.I.X. play, setting repeat play to ON will cancel the M.I.X. play.
- During repeat play, etc., the track number display for M.I.X. play may be incorrect.

## Searching for a desired Song

A USB Memory or Portable audio player can contain hundreds of songs. By using file tag information and keeping these songs organized in playlists, this unit's search functions will ease song searches. Each music category has its own individual hierarchy. Use the Bank/Playlists\*1/Artists/Albums/Songs/Genres/Composers/Folders/Files search mode to narrow searches based on the table below.

Hierarchy 1	Hierarchy 2	Hierarchy 3	Hierarchy 4	Hierarchy 5
Bank	Playlist*1	Song	—	—
Bank	Artist*	Album*	Song	—
Bank	Album*	Song	—	—
Bank	Song	—	—	—
Bank	Genre*	Artist*	Album*	Song
Bank	Composer*	Album*	Song	—
Bank	Folder	File	—	—
Bank	File	—	—	—

\*1 Playlist search is not available when a Portable audio player is connected.

**For example:**

Searching by Artist name

The following example explains how an Artists search is performed. Another search mode can be used for the same operation, although the hierarchy differs.

### Searching by artist name

**1** Press ENTER/Q to activate the search selection mode.

**2** Turn the Rotary encoder to select a desired Bank, and then press ENTER/Q.

The "Banking" may be displayed for a few seconds.

**3** Turn the Rotary encoder to select the Artist search mode, and then press ENTER/Q.

Playlist ↔ Artist ↔ Album ↔ Song ↔ Genre ↔ Composer ↔ Folder ↔ File ↔ Playlist



**4** Turn the Rotary encoder to select the desired Artist, and then press ENTER/Q.

**5** Turn the Rotary encoder to select an album, and then press ENTER/Q.

**6** Turn the Rotary encoder to select a song and press ENTER/Q.

The selected song is played back.

**Notes**

- After pressing and holding ENTER/Q for at least 2 seconds while in each hierarchy (except Song and File hierarchy), all songs of the selected hierarchy are played back.
- After selecting [ALL] in the search mode with "a", press and hold ENTER/Q for at least 2 seconds to play back all songs in the selected search mode.
- While in the search mode, if you press and hold /ESC for at least 2 seconds, or no operation is performed for 60 seconds, the search mode is canceled.
- The root folder of USB Memory/Portable audio player is displayed as "\ROOT".
- When the bank is changed during Repeat play, the Repeat play will be canceled.
- In the search mode, pressing /ESC will return to the previous mode.
- When search is made during M.I.X. play, the M.I.X. play mode will be canceled.
- In the search mode, a search can be made quickly by Alphabet skip function to find the desired artist or song, etc. For details, refer to "Alphabet Skip Function" on page 32.
- When searching for a song, artist, etc., in a USB Memory, the display order may be incorrect if the character code of the file tag information is mixed.

## Select Playlist\*/Artist/Album/Genre/Composer/Folder

Playlist\*/Artist/Album/Genre/Composer/Folder can be easily changed. For example, if you listen to a song from a selected album, the album can be changed.

**1** Press ◀ or ▶ to select the desired Playlist\*/Artist/Album/Genre/Composer/Folder.

\* This item is invalid when a portable audio player is connected.

**Notes**

- If the song search mode was used to select a song, this function is inactive.
- If an album is selected during an artist search, other albums by that artist are searchable.
- This function is inactive during shuffle (M.I.X.) playback.

## Alphabet Skip Function

The initial skip function is skipped to the next number, symbol or letter such as from A to B, B to C.

You can skip in reverse order such as B to A by pressing ◀.

- 1 During search mode, press ◀ or ▶ to perform the Alphabet Skip Function.

A list is skipped to the next number, symbol or letter.

### Notes

- The alphabet select object is only the alphabet that is recorded by UTF-16 character code.
- If the Song search mode is activated in Playlist search, this function is invalid.

## Quick Search

You can search a song from all songs in current bank of USB Memory/portable audio player without selecting an album, artist, etc.

- 1 Press and hold ENTER/Q for at least 2 seconds to activate Quick Search mode.
- 2 Turn the Rotary encoder to select a desired track (file).  
The selected track is played back immediately.

### Note

- Press ↵/ESC in the search mode to cancel. Or, the search mode is canceled if no operation is performed for 10 seconds.

## Search Position Memory

During playback, you can quickly return to the last-selected hierarchy level in the search mode.

- 1 Press ↵/ESC.  
The hierarchy you selected last in the search mode is displayed.

## iPhone/iPod (optional)

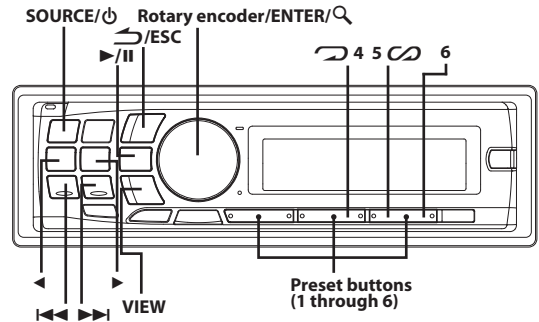

## Connecting an iPhone/iPod

An iPhone/iPod can be connected to this unit by using the Interface cable for iPod (supplied). When this unit is connected by using the cable, the controls on the iPod are not functional.

### Notes

- Internet and telephone functions of the iPod touch or iPhone, etc., can also be used while connected to this unit. Using these functions will stop or pause the currently playing songs. During this time, do not operate the unit to avoid a malfunction.
- If you connect an iPhone to this unit, it can be used as an iPod. If you use iPhone as a hands-free phone, you need the optional BLUETOOTH INTERFACE (KCE-400BT).

### iPhone/iPod models usable with this unit

- Confirmed devices regarding Made for iPod. Correct function of earlier versions cannot be guaranteed.
  - iPod touch (2nd generation): Ver.3.0
  - iPod nano (4th generation): Ver.1.0.2
  - iPod classic (120 GB only): Ver.2.0.1
  - iPod touch (1st generation): Ver.3.0
  - iPod nano (3rd generation): Ver.1.1.3 PC
  - iPod classic (80 GB, 160 GB only): Ver.1.1.2 PC
  - iPod nano (2nd generation): Ver.1.1.3
  - iPod with video: Ver.1.3
  - iPod nano (1st generation): Ver.1.3.1
- Confirmed devices regarding Works with iPhone. Correct function of earlier versions cannot be guaranteed.
  - iPhone 3GS: Ver.3.1
  - iPhone 3G: Ver.3.0
  - iPhone: Ver.3.0
- For clarity in identifying your model of iPod, please see Apple's own document "Identifying iPod models" at <http://support.apple.com/kb/HT1353>.
- This unit does not support video playback from iPhone/iPod, even using a video-compatible cable.

## Playback

**1** Press **SOURCE/⏻** to switch to the USB iPod mode.

**2** Press **I◀◀** or **▶▶I** to select the desired song.

Pressing and holding **I◀◀** or **▶▶I** will fast backward/fast forward the current song.

**3** To pause playback, press **▶/II**.

Pressing **▶/II** again will resume playback.

### Notes

- A song playing on the iPhone/iPod while it is connected to this unit will continue to play from where it was paused after disconnection.
- If you listen to an episode from a selected podcast or audiobook, the episode can be changed by pressing **◀** or **▶**.
- An episode may have several chapters. The chapter can be changed by pressing **I◀◀** or **▶▶I**.
- When an iPhone 3GS or an iPod (Ver.3.x) is connected to this unit, after changing the source or received traffic information, etc., to return to USB iPod mode, "No USB Unit" may be displayed. In this case, reconnect the iPhone 3GS/iPod.

## Searching for a desired Song

An iPhone/iPod can contain hundreds of songs. By using file tag information and keeping these songs organised in playlists, this unit's search functions will ease song searches.

Each music category has its own individual hierarchy. Use the Playlist/Artist/Album/Song/Podcast/Genre/Composer/Audiobook search mode to narrow searches based on the table below.

Hierarchy 1	Hierarchy 2	Hierarchy 3	Hierarchy 4
Playlist	Song	—	—
Artist*	Album*	Song	—
Album*	Song	—	—
Song	—	—	—
Podcast	Episode	—	—
Genre*	Artist*	Album*	Song
Composer*	Album*	Song	—
Audiobook	—	—	—

### For example:

Searching by Artist name.

The following example explains how an Artist search is performed.

Another search mode can be used for the same operation, although the hierarchy differs.

## Searching by artist name

**1** Press **ENTER/Q** to activate the search selection mode.

**2** Turn the **Rotary encoder** to select the Artist search mode, and then press **ENTER/Q**.

Playlist ↔ Artist ↔ Album ↔ Song ↔ Podcast ↔ Genre ↔ Composer ↔ Audiobook ↔ Playlist

**3** Turn the **Rotary encoder** to select the desired Artist, and then press **ENTER/Q**.

**4** Turn the **Rotary encoder** to select the desired Album, and then press **ENTER/Q**.

**5** Turn the **Rotary encoder** to select the desired Song, and then press **ENTER/Q**.

The selected song is played back.

### Notes

- After pressing and holding **ENTER/Q** for at least 2 seconds while in each hierarchy (except Song and Audiobook hierarchy), all songs of the selected hierarchy are played back.
- After selecting [ALL] in the search mode with **⌘**, press and hold **ENTER/Q** for at least 2 seconds to play back all songs in the iPhone/iPod or selected search mode.
- While in the search mode, if you press and hold **↶/ESC** for 2 seconds, or no operation is performed for 60 seconds, the search mode is canceled.
- In the search mode, pressing **↶/ESC** will return to the previous mode.
- When search is made during M.I.X. play, the M.I.X. play mode will be canceled.
- "No Song" will be displayed if there are no songs in the selected playlist in the Playlist search mode.
- "No Podcast" will be displayed if there is no podcast data in the iPhone/iPod in the Podcast search mode.
- "No Audiobook" will be displayed if there is no audiobook data in the iPhone/iPod in the Audiobook search mode.
- If "iPod name" stored in the iPhone/iPod is selected in the desired Playlist search mode, and **ENTER/Q** is pressed, you can search for all songs in the iPhone/iPod. Also, if you press and hold **ENTER/Q** for at least 2 seconds, all songs in the iPhone/iPod are played back.
- Depending on the iPhone/iPod, podcast search is not supported.
- If Alphabet Skip Function is activated in the search mode, a search can be made quickly by Alphabet skip function to find the desired artist or song, etc. For details, refer to "Alphabet Skip Function" on page 34.
- If any one of the **preset buttons (1 through 6)** is pressed in the search mode, a search can be made quickly by skipping to the specified location. For details, refer to "Direct Search Function" on page 34.

## Quick Search

You can search a song from all songs in the iPhone/iPod without selecting an album, artist, etc.

**1** Press and hold **ENTER/Q** for at least 2 seconds to activate the Quick Search mode.

**2** Turn the **Rotary encoder** to select a desired song.

The selected song is played back immediately.

### Notes

- Press **↶/ESC** in the search mode to cancel. Or, the search mode is canceled if no operation is performed for 10 seconds.
- If many songs are in iPhone/iPod, it takes time to search for songs.
- If any one of the **preset buttons (1 through 6)** is pressed in the search mode, a search can be made quickly by skipping to the specified location. For details, refer to "Direct Search Function" on page 34.
- This function is inactive during repeat (RPT) playback.

---

## Direct Search Function

---

The unit's direct search function can be used to search for an album, song, etc., more efficiently. In Playlist/Artist/Album/Song/Podcast/Genre/Composer/Audiobook mode, you can quickly target any song.

- 1 In the search mode, press any one of the preset buttons (1 through 6) to quickly skip over a designated percent of your song content.

### Song search example:

If there are 100 songs in your iPhone/iPod, they are divided into 6 groups using percentages (shown below). These groups are assigned to preset buttons 1 through 6.

### Example 1:

Suppose the song you are searching for is located at around the middle (50%) of your library: press button 4 to jump to the 50th song and turn the **Rotary encoder** to find the desired song.

### Example 2:

Suppose the song you are searching for is located near the end (83%) of your library: press button 6 to jump to the 83rd song and turn the **Rotary encoder** to find the desired song.

	All 100 songs (100%)					
	0%	17%	33%	50%	67%	83%
Preset buttons	1	2	3	4	5	6
Songs	1st song	17th song	33rd song	50th song	67th song	83rd song

---

## Select Playlist/Artist/Album/Genre/Composer/Episode

---

Playlist/Artist/Album/Genre/Composer/Episode can be easily changed. For example, if you listen to a song from a selected album, the album can be changed.

- 1 Press ◀ or ▶ to select the desired Playlist/Artist/Album/Genre/Composer/Episode.

### Notes

- If the song search mode was used to select a song, this function is inactive.
- If an album is selected during an artist search, other albums by that artist are searchable.
- This function is inactive during shuffle (M.I.X.) playback.

---

## Alphabet Skip Function

---

The initial skip function is skipped to the next number, symbol or letter such as from A to B, B to C.

You can skip in reverse order such as B to A by pressing ◀.

- 1 During search mode, press ◀ or ▶ to perform the Alphabet Skip Function.

A list is skipped to the next number, symbol or letter.

### Note

- Titles are listed alphabetically, and can be skipped every 200 titles. If there are fewer than 200 titles, titles beginning with the next alphabetical character are selected.

---

## Search Position Memory

---

During iPhone/iPod playback, you can quickly return to the last-selected hierarchy level in the search mode.

- 1 Press ↶ / ESC.

The hierarchy you selected last in the search mode is displayed.

---

## Random Play Shuffle (M.I.X.)

---

The Shuffle function of the iPhone/iPod is displayed as M.I.X. on this unit.

### Shuffle Albums:



The songs on each album are played back in proper order. Upon completion of all the songs on the album, the next album is selected randomly. This continues until all albums have been played.

### Shuffle Songs:

Song shuffle randomly plays back songs within a selected category (playlist, album, etc.). The songs within the category are played just once until all songs have been played.

- 1 Press 5 .

The songs are played back in random sequence.

MIX \*1 → MIX\*2 → (off) → MIX 

\*1 Shuffle Albums.

\*2 Shuffle Songs.

- 2 To cancel M.I.X. play, select (off) with the above procedure.

### Note

- If a song is selected in the album search mode before selecting M.I.X. play, the songs will not play back randomly even when Shuffle Albums is selected.

### Shuffle ALL:

Shuffle ALL plays all songs in the iPhone/iPod randomly. Any one song does not play back again until all songs have been played back.

- 1 Press 6.

The songs are played back in random sequence.

MIX ALL\* → (off) → MIX ALL

\* Shuffle ALL.

- 2 To cancel M.I.X. play, select (off) with the above procedure.

### Note

- If Shuffle ALL is selected, the selected songs being played back in the search mode are canceled.

---

## Repeat Play

---

Only Repeat One is available for the iPhone/iPod.

### Repeat One:

A single song is repeatedly played back.

- 1 Press  4.

The song is played back repeatedly.

RPT\* → (off) → RPT

\* Repeat One.

- 2 To cancel repeat play, select (off) with the above procedure.

## Note

- Depending on the connected iPod, track up/down may be not available during Repeat play.

## Displaying the Text

You can display the tag information of a song in the iPhone/iPod.

### 1 Press VIEW.

Each press changes the display.

#### Note

- When the Text Scroll is set to Manual, press and hold **VIEW** for at least 2 seconds, the current text will be scrolled one time.

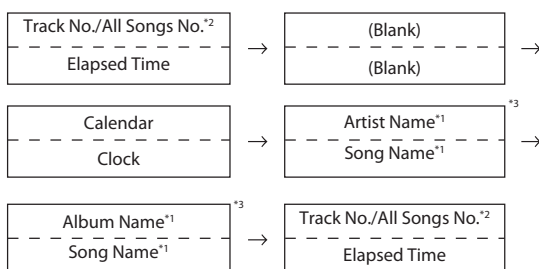

#### \*1 TAG information

If the Text Scroll (refer to "Scroll Setting (Text Scroll)" on page 23) is set to "Auto," the tag information will scroll automatically.

If there is no text information, nothing will be displayed.

#### \*2 The numbers of all songs displayed vary depending on the songs selected by the search.

#### \*3 When the Text Scroll (refer to "Scroll Setting (Text Scroll)" on page 23) is set to "Auto," the display cannot be switched by pressing **VIEW**. The display contents switch alternately.

## Notes

- Only alphanumeric characters (ASCII) can be displayed.
- The maximum number of characters for the head unit is 128 (128 byte).
- Some characters may not be correctly displayed.
- The display is blank when text information is not compatible with this unit.

## IMPRINT Operation (optional)

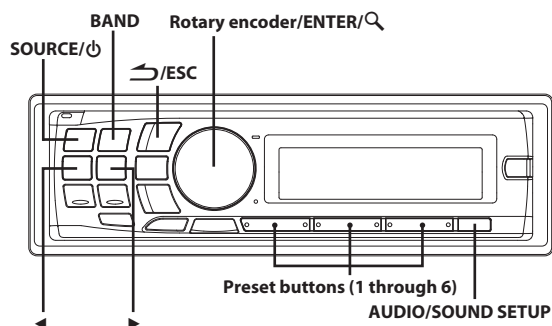

Alpine introduces IMPRINT - the world's first technology that thoroughly eliminates in-car acoustic problems that normally degrade sound quality, which enables us to experience music the way the artist intended.

When the IMPRINT audio processor (PXA-H100) (sold separately) is connected to this unit, MultEQ and the following sound adjustment can be performed.

## Changing MultEQ mode

MultEQ, developed by Audyssey Labs, automatically corrects the audio for the listening environment. The system is optimized for selected positions in the vehicle. To accomplish this, MultEQ must take measurements of the vehicles response characteristics. For details on the set up procedure, consult your authorized Alpine dealer.

- Press and hold **SOUND SETUP** for at Least 2 seconds to activate the Sound menu selection mode.
- Turn the **Rotary encoder** to select MultEQ Mode, and then press **ENTER/Q**.
- Turn the **Rotary encoder** to select the desired MultEQ mode, and then press **ENTER/Q**.

OFF (Manual Mode) ↔ Curve 1 (MultEQ-1) ↔ Curve 2 (MultEQ-2)

## Notes

- The Curve mode can be selected only when Curve 1 and Curve 2 are stored.
- When using MultEQ, MX, X-Over, T.Correction, Factory's EQ, SUBW. Phase, SUBW. Channel, TW Setup, EQ Mode, Filter Type and Parametric EQ/Graphic EQ are set automatically. They are no longer user adjustable.
- When an external audio processor is connected, the MultEQ function cannot be used.

## Adjusting Subwoofer Level/Bass Level/ Treble Level/Fader (Between Front and Rear)/Balance (Between Left and Right)/ Black Out in MultEQ mode

You can change these settings to create your own preference in MultEQ (Curve 1 or Curve 2) mode.

### 1 Press **AUDIO** repeatedly to select the MultEQ adjustment item.

SUBWOOFER LEVEL\*<sup>1</sup> → BASS LEVEL\*<sup>2</sup> → TREBLE LEVEL\*<sup>2</sup> →  
BALANCE → FADER\*<sup>3</sup> → BLACK OUT\*<sup>4</sup> → DEFEAT → VOLUME →  
SUBWOOFER LEVEL

\*1 When the SUBWOOFER mode is set to OFF, its level cannot be adjusted.

\*2 This function is inoperable when MultEQ is set to OFF.

\*3 If you set the 2.2ch (3WAY)/4.2ch (FRONT/REAR/SUBW.) switch of the IMPRINT audio processor (PXA-H100) to 2.2ch (3WAY), you cannot adjust the FADER mode. For details, refer to the Owner's Manual of PXA-H100.

\*4 When Blackout mode is turned on, all display indications on this unit will turn off to reduce power consumption. This additional power enhances the sound quality. If any button on the unit is pressed during the Blackout Mode, the function is displayed for 5 seconds before returning to Blackout mode.

#### Note

- If no operation is performed for 5 seconds after selecting the SUBWOOFER LEVEL, BASS LEVEL, TREBLE LEVEL, FADER, BALANCE, BLACK OUT or DEFEAT mode the unit automatically returns to normal mode.

### 2 Turn the Rotary encoder to change the setting as below.

Subwoofer level	0 ~ 15
Bass level	-7~+7
Treble level	-7~+7
Balance	-15 (L) ~ 15 (R)
Fader	-15 (R) ~ 15 (F)
Black Out	ON/OFF
Defeat	ON/OFF
Volume	0 ~ 35

#### Note

- Depending on the connected devices, some functions and display indications do not work.

## Adjusting Sound Setting in Manual Mode

You can change these sound settings to create your own preference when the MultEQ mode is set to Mult EQ OFF (Manual Mode).

**Use steps 1 to 4 to select one of the Sound menu modes to modify. See the applicable section below for details about the selected item.**

### 1 Press and hold **SOUND SETUP** for at Least 2 seconds to activate the Sound menu selection mode.

### 2 Turn the Rotary encoder to select the desired item, and then press **ENTER/Q**.

MultEQ Mode ↔ Subwoofer ↔ SUBW. System\*<sup>1</sup> ↔ SUBW. Phase\*<sup>1</sup>  
↔ SUBW. Channel\*<sup>1</sup> ↔ Factory's EQ ↔ TW Setup\*<sup>2</sup> ↔ Filter Type  
↔ Media Xpander ↔ MX Level\*<sup>3</sup> ↔ EQ Mode ↔ TCR Parameter  
↔ Sound Field\*<sup>4</sup> ↔ MultEQ Mode

(e.g. Select Subwoofer)

\*1 These functions are inoperable when Subwoofer is set to OFF.

\*2 This function can be operable only when PXA-H100 (sold separately) is connected and 2.2ch (3WAY) mode is set. For details, refer to the Owner's Manual of PXA-H100.

\*3 This function is inoperable when Media Xpander is set to OFF.

\*4 In step 2, three sound adjustment items (Parametric EQ/Graphic EQ, T.Correction, X-Over) can be selected in Sound Field Adjustment mode, turn the **Rotary encoder** to select the desired item, and then press **ENTER/Q** to continue to step 3.

### 3 Turn the Rotary encoder to change the setting, and then press **ENTER/Q**.

(e.g. Select Subwoofer ON or Subwoofer OFF)

### 4 Press and hold **↵/ESC** for at least 2 seconds to return to normal mode.

#### Notes

- Media Xpander, Factory's EQ, Parametric EQ/Graphic EQ, EQ Mode and MX Level Adjustment are inoperable when DEFEAT is set to ON.
- Pressing **↵/ESC** returns to the previous Sound menu mode.
- If no operation is performed for 60 seconds, Sound menu mode is canceled.

## Turning Subwoofer ON/OFF

When the subwoofer is on, you can adjust the subwoofer output level.

### Setting item: Subwoofer

#### Setting contents:

ON (Initial setting) / OFF

#### ON:

The subwoofer signal is output from the Subwoofer RCA Connectors (refer to "Connections" on page 52).

#### OFF:

No subwoofer signal is output from the Subwoofer RCA Connectors (refer to "Connections" on page 52).

## Setting the Subwoofer System

When the subwoofer is on, you can select either System 1 or System 2 for the desired subwoofer effect.

### Setting item: SUBW. System

#### Setting contents:

System 1 (Initial setting) / System 2

#### System 1:

Subwoofer level changes according to the main volume setting.

#### System 2:

Subwoofer level change is different from the main volume setting. For example, even at low volume settings, the subwoofer is still audible.

## Setting the Subwoofer Phase

The subwoofer output phase is toggled SUBWOOFER NORMAL (0°) or SUBWOOFER REVERSE (180°). To adjust the level, turn the **Rotary encoder**.

■ **Setting item:** SUBW. Phase

**Setting contents:**

PHASE 0° (Initial setting) / PHASE 180°

## Setting the Subwoofer Channel (SUBW. Channel)

You can set the subwoofer output to stereo or monaural. Make sure to set the correct output for your subwoofer type.

■ **Setting item:** SUBW. Channel

**Setting contents:**

STEREO (Initial setting) / MONO

**STEREO:**

Subwoofer stereo (L/R) output

**MONO:**

Subwoofer monaural output

## Equalizer Presets (Factory's EQ)

10 typical equalizer settings are preset at the factory for a variety of musical source material.

Flat ↔ Pops ↔ Rock ↔ News ↔ Jazz&Blues ↔ Electrical Dance  
↔ Hip Hop&Rap ↔ Easy Listening ↔ Country ↔ Classical ↔  
User1 ↔ User2 ↔ User3 ↔ User4 ↔ User5 ↔ User6

### Note

- By selecting User's 1 to 6, you can recall the stored preset number (refer to "Adjusting the Graphic Equalizer Curve" on page 38 or refer to "Adjusting the Parametric Equalizer Curve" on page 38).

## Setting the Response Slope for the High Range Speaker (TW Setup)

Setting the response characteristic of tweeter to FLAT in 2.2ch (3WAY) mode could damage the speaker. Make sure the Crossover cut-off is appropriate for the tweeter being used (Refer to "Adjusting the Crossover Settings" on page 38).

■ **Setting item:** TW Setup

**Setting contents:**

FACTORY'S (Initial setting) / USER'S

**FACTORY'S:**

As protection from possible speaker damage, FLAT cannot be set for the response slope of the high range speaker in 2.2ch (3WAY) mode.

**USER'S:**

The FLAT setting is possible in 2.2ch (3WAY) mode.

## Setting the Filter type

■ **Setting item:** Filter Type

**Setting contents:**

NORMAL (Initial setting) / INDIVIDUAL

**NORMAL (L=R):**

Left and right speakers are adjusted equally.

**INDIVIDUAL (L/R):**

Left and right speakers are individually adjusted.

## Turning Media Xpander ON/OFF

When the Media Xpander is on, you can adjust the Media Xpander level (refer to "Setting the MX Level" on page 37).

■ **Setting item:** Media Xpander

**Setting contents:**

OFF (Initial setting) / ON

## Setting the MX Level

MX (Media Xpander) makes vocals or instruments sound distinct regardless of the music source. The FM radio, CD, USB Memory and iPhone/iPod, will be able to reproduce the music clearly even in cars with a lot of road noise.

### 1 Changing the source to which you want to apply Media Xpander.

**FM (MX level 1 to 3):**

The medium to high frequencies become clearer, and produces well balanced sound at all frequencies.

**CD (MX level 1 to 3):**

CD mode processes a large amount of data during playback. MX takes advantage of this large data quantity to reproduce a more clear, clean output.

**CMPM/SAT (MX level 1 to 3):**

This corrects information that was lost at the time of compression. This reproduces a well-balanced sound close to the original.

**DVD (Video CD) (MOVIE MX level 1 to 2):**

The dialogue portion of a video is reproduced more clearly.

**(DVD MUSIC):**

A DVD or Video CD contains a large quantity of data such as music clip. MX uses this data to reproduce the sound accurately.

**AUX (MX level 1):**

Choose the MX mode (CMPM, MOVIE, or MUSIC) that corresponds to the media connected.

### Notes

- Each music source, such as FM radio, CD, and MP3/WMA/AAC can have its own MX setting.
- On disks with both MP3/WMA/AAC and CD-DA, when the source changes from "MP3/WMA/AAC to CD-DA" or "CD-DA to MP3/WMA/AAC", MX-mode switching may delay playback slightly.
- Setting to Non Effect sets MX mode of each music source to OFF.
- The function is inoperable when DEFEAT is set to ON.
- There is no MX mode for AM radio.
- If an audio processor with the MX function (PXA-H701, etc.) is connected, its own MX processing is applied to the music source. Since the processor MX settings may not match the head unit, the audio processor needs to be adjusted. For details, refer to the Owner's Manual of the audio processor.
- "CMPM" is applied for MP3/WMA/AAC and iPhone/iPod.
- "SAT" is applied for XM radio and SIRIUS radio.

## Setting EQ mode

This setting gives you a choice of 5-band parametric, or 7-band graphic equalizer.

■ **Setting item:** EQ Mode

**Setting contents:**

Parametric EQ (Initial setting) / Graphic EQ

**PEQ:**

5-band Parametric EQ

**GEQ:**

7-band Graphic EQ

## Setting the Time Correction Unit (TCR Parameter)

You can change the unit, (cm or inch) of time correction.

### Setting item: TCR Parameter

**Setting contents:**  
cm (Initial setting) / inch

## Sound Field Adjustment

The setting of Parametric EQ/Graphic EQ, Time Correction and X-Over can be adjusted in this mode.

### Adjusting the Parametric Equalizer Curve

You can modify the Equalizer settings to create a response curve more appealing to your personal taste. To adjust the Parametric Equalizer Curve, set the EQ Mode to Parametric EQ. For details, refer to "Setting EQ mode" on page 37.

#### 1 After selecting Parametric EQ from the Sound Field Adjustment mode, press **BAND** to select the band to be adjusted.

Band 1 → Band 2 → Band 3 → Band 4 → Band 5 → Band 1

#### 2 Press ◀ or ▶ to select frequency bands.

Adjustable frequency bands: 20 Hz to 20 kHz (in 1/3 octave steps).

Band-1	20 Hz~80 Hz (63 Hz)
Band-2	50 Hz~200 Hz (150 Hz)
Band-3	125 Hz~3.2 kHz (400 Hz)
Band-4	315 Hz~8 kHz (1 kHz)
Band-5	800 Hz~20 kHz (2.5 kHz)

#### 3 Turn the Rotary encoder to adjust the level.

Adjustable level: -6 to +6 dB

#### 4 Press **SOURCE** / **⏻** to set the bandwidth (Q).

Adjustable bandwidth: 1, 1.5, 3

#### 5 To adjust another band, repeat steps 1 to 4 and adjust all bands.

#### Notes

- The frequencies of adjacent bands cannot be adjusted within 4 steps.
- While adjusting the Parametric EQ, you should consider the frequency response of the connected speakers.

### Adjusting the Graphic Equalizer Curve

You can modify the equalizer settings to create a response curve more appealing to your personal taste. To adjust the graphic equalizer curve, set the EQ Mode to Graphic EQ. For details, refer to "Setting EQ mode" on page 37.

#### 1 After selecting Graphic EQ from the Sound Field Adjustment mode, press **BAND** to select the band to be adjusted.

Band 1 → Band 2 → Band 3 → Band 4 → Band 5 → Band 6 → Band 7 → Band 1

Band-1	63 Hz
Band-2	150 Hz

Band-3	400 Hz
Band-4	1 kHz
Band-5	2.5 kHz
Band-6	6.3 kHz
Band-7	17.5 kHz

#### 2 Turn the Rotary encoder to adjust the level.

Adjustable output level: -6 to +6 dB

#### 3 To adjust another band, repeat steps 1 and 2, and then adjust all bands.

### Adjusting the Time Correction

Before performing the following procedures, refer to "About Time Correction" on page 39.

#### 1 After selecting T.Correction from the Sound Field Adjustment mode, press **BAND** to select a speaker to be adjusted.

#### 2.2ch (3WAY) System

F-L\*<sup>1</sup> → F-R\*<sup>2</sup> → R-L\*<sup>3</sup> → R-R\*<sup>4</sup> → SW-L → SW-R → F-L

\*1 Mid-L (Initial setting)

\*2 Mid-R

\*3 High-L

\*4 High-R

#### 4.2ch (FRONT/REAR/SUBW.) System

F-L\*<sup>1</sup> → F-R\*<sup>2</sup> → R-L\*<sup>3</sup> → R-R\*<sup>4</sup> → SW-L → SW-R → F-L

\*1 Front-L (Initial setting)

\*2 Front -R

\*3 Rear-L

\*4 Rear-R

#### 2 Turn the Rotary encoder to adjust the distance correction value (0.0 to 336.6cm).

L = (distance to farthest speaker) - (distance to other speakers)

#### 3 Repeat steps 1 and 2 to set another speaker.

By setting these values to make its sound reach the listening position at the same time as the sound of other speakers.

### Adjusting the Crossover Settings

Before performing the following procedures, refer to "About the Crossover" on page 41.

#### 2.2ch (3WAY) System

#### 1 After selecting X-Over from the Sound Field Adjustment mode, press **BAND** to select the band to be adjusted.

NORMAL (L=R)

**Setting items:** LOW / MID-L / MID-H / HIGH  
INDIVIDUAL (L/R)

**Setting items:** LOW-L / LOW-R / MID-L-L / MID-L-R / MID-H-L / MID-H-R / HIGH-L / HIGH-R

#### 2 Press ◀ or ▶ to select the desired cut-off frequency (Crossover Point).

Adjustable frequency bands:

LOW / MID-L	20 Hz~200 Hz
-------------	--------------



MID-H	20 Hz~20 kHz
HIGH	(1 kHz~20 kHz) <sup>*1</sup> /(20 Hz~20 kHz) <sup>*2</sup>

\*1 When FACTORY'S is selected, refer to "Setting the Response Slope for the High Range Speaker (TW Setup)" on page 37.

\*2 When USER'S is selected, refer to "Setting the Response Slope for the High Range Speaker (TW Setup)" on page 37.

### 3 Press SOURCE/ to adjust the slope.

Adjustable slope: FLAT\*, 6 dB/oct., 12 dB/oct., 18 dB/oct., 24 dB/oct.

\* FLAT can be set for the HIGH slope only when TW Setup is set to USER'S (refer to "Setting the Response Slope for the High Range Speaker (TW Setup)" on page 37). Depending on the response characteristics of the speaker, care should be taken when setting the response slope to FLAT, as speaker damage may result. With this unit, a message is displayed when the response slope for the high range speaker is set to FLAT.

### 4 Turn the Rotary encoder to adjust the output level.

Adjustable output level: -12 to 0 dB.

### 5 Repeat steps 1 to 4 to make adjustment to the other bands.

#### 4.2ch (FRONT/REAR/SUBW.) System

#### 1 After selecting X-Over from the Sound Field Adjustment mode, press BAND to select the band to be adjusted.

NORMAL (L=R)

■ **Setting items:** LOW (SUB-W) / MID (REAR) / HIGH (FRONT)

INDIVIDUAL (L/R)

■ **Setting items:** LOW (SUB-W)-L / LOW (SUB-W)-R / MID (REAR)-L / MID (REAR)-R / HIGH (FRONT)-L / HIGH (FRONT)-R

#### 2 Press ◀ or ▶ to select the desired cut-off frequency (Crossover Point).

Adjustable frequency bands: 20 Hz~200 Hz

#### 3 Press SOURCE/ to adjust the slope.

Adjustable slope: FLAT, 6 dB/oct., 12 dB/oct., 18 dB/oct., 24 dB/oct.

#### 4 Turn the Rotary encoder to adjust the output level.

Adjustable output level: -12 to 0 dB.

#### 5 Repeat steps 1 to 4 to make adjustment to the other bands.

#### Notes

- While adjusting the X-Over, you should consider the frequency response of the connected speakers.
- About the 2.2ch (3WAY)/4.2ch (FRONT/REAR/SUBW.) system, you can switch to 2.2ch (3WAY)/4.2ch (FRONT/REAR/SUBW.) system mode with the 2.2ch (3WAY)/4.2ch (FRONT/REAR/SUBW.) switch on the PXA-H100. For details, refer to the Owner's Manual of PXA-H100.

### Storing the Sound Field Adjustment Settings

The Sound Field Adjustment Settings containing Parametric EQ/ Graphic EQ, T.Correction and X-Over settings can be stored in the preset memory.

#### 1 When the settings of Sound Field Adjustment have been completed, select any one of the preset buttons (1

through 6) in any item of the Sound Field Adjustment mode (e.g. X-Over), press and hold the desired preset buttons for at least 2 seconds.

#### 2 Turn the Rotary encoder to select PROTECT YES/NO, and then press ENTER/ to store the adjusted contents.

PROTECT YES (Initial setting) ↔ PROTECT NO

#### Notes

- If YES is selected, the adjusted contents are protected and stored into the preset buttons. When you want to store the parameter into a protected preset button, "Replace NO/YES" can be selected.
- If NO is selected, the preset is stored.
- While performing this operation, all adjusted contents of Parametric EQ/Graphic EQ, T.Correction and X-Over will be stored in the preset buttons.
- The stored contents are not deleted even when resetting the unit or disconnecting the battery.
- The stored contents can be recalled by performing operation (refer to "Recalling the Stored Sound Field Adjustment Settings" on page 39).

### Recalling the Stored Sound Field Adjustment Settings

The stored Sound Field Adjustment Settings contain Parametric EQ/ Graphic EQ, T.Correction and X-Over settings that are stored in the preset memory.

#### 1 After selecting any item of the Sound Field Adjustment mode (e.g. X-Over), press any one of the preset buttons (1 through 6) that has your desired characteristic in memory to recall the stored settings.

#### 2 Press the preset buttons (1 through 6) again to return to the Sound Field Adjustment mode.

#### Note

- While performing this operation, all adjustment contents of Parametric EQ/Graphic EQ, T.Correction and X-Over stored in the preset buttons will be recalled.

### About Time Correction

The distance between the listener and the speakers in a car vary widely due to the complex speaker placement. This difference in the distances from the speakers to the listener creates a shift in the sounds image and frequency characteristics. This is caused by the time delay between the sound reaching the listener's right versus the left ear.

To correct this, this unit is able to delay the audio signal to the speakers closest to the listener. This effectively creates a perception of increased distance for those speakers. The listener can be placed at an equal distance between the left and right speakers for optimum staging. The adjustment will be made for each speaker in 3.4cm steps.

Listening Position example as follows:

## Example 1: Front Left Seat

Adjust the time correction level of the front left speaker to a high value and the rear right to zero or a low value.

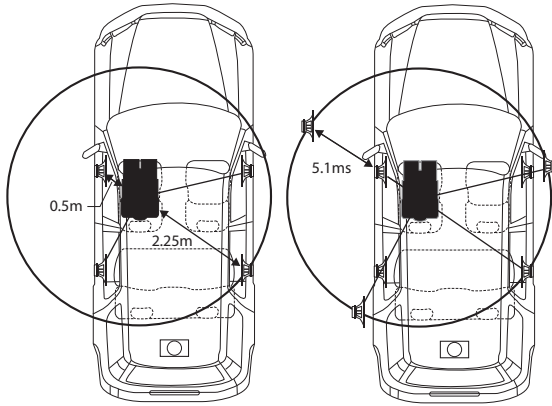

The sound is not balanced because the distance between the listening position and the various speakers is different.

The difference in distance between the front left speaker and the rear right speaker is 1.75 m (68-7/8").

Here we calculate the time correction value for the front left speaker in the diagram on the above.

### Conditions:

Farthest Speaker - listening position : 2.25 m (88-9/16")

Front left speaker - listening position : 0.5 m (19-11/16")

Calculation:  $L = 2.25 \text{ m} - 0.5 \text{ m} = 1.75 \text{ m}$  (68-7/8")

Time correction =  $1.75 \div 343^{*1} \times 1000 = 5.1 \text{ (ms)}$

\*1 Speed of sound: 343 m/s (765 mph) at 20°C

In other words, giving the front left speaker a time correction value of 5.1 ms makes it seem as if its distance from the listener is the same as the distance to the farthest speaker.

Time correction eliminates the differences in the time required for the sound to reach the listening position.

The time of the front left speaker is corrected by 5.1 ms so that its sound reaches the listening position at the same time as the sound of other speakers.

## Example 2: All Seats

Adjust the time correction level of each speaker to almost the same level.

**1** Sit in the listening position (driver's seat, etc.) and measure the distance (in meters) between your head and the various speakers.

**2** Calculate the difference between the distance correction value to the farthest speaker and the other speakers.

$L = (\text{distance to farthest speaker}) - (\text{distance to other speakers})$

These values are the time correction values for the different speakers. Setting these values to make each sound reach the listening position at the same time as the sound of other speakers.

### Time Correction Value List

Delay Number	Time Difference (ms)	Distance (cm)	Distance (inch)
0	0.0	0.0	0.0
1	0.1	3.4	1.3
2	0.2	6.8	2.7

Delay Number	Time Difference (ms)	Distance (cm)	Distance (inch)
3	0.3	10.2	4.0
4	0.4	13.6	5.4
5	0.5	17.0	6.7
6	0.6	20.4	8.0
7	0.7	23.8	9.4
8	0.8	27.2	10.7
9	0.9	30.6	12.1
10	1.0	34.0	13.4
11	1.1	37.4	14.7
12	1.2	40.8	16.1
13	1.3	44.2	17.4
14	1.4	47.6	18.8
15	1.5	51.0	20.1
16	1.6	54.4	21.4
17	1.7	57.8	22.8
18	1.8	61.2	24.1
19	1.9	64.6	25.5
20	2.0	68.0	26.8
21	2.1	71.4	28.1
22	2.2	74.8	29.5
23	2.3	78.2	30.8
24	2.4	81.6	32.2
25	2.5	85.0	33.5
26	2.6	88.4	34.8
27	2.7	91.8	36.2
28	2.8	95.2	37.5
29	2.9	98.6	38.9
30	3.0	102.0	40.2
31	3.1	105.4	41.5
32	3.2	108.8	42.9
33	3.3	112.2	44.2
34	3.4	115.6	45.6
35	3.5	119.0	46.9
36	3.6	122.4	48.2
37	3.7	125.8	49.6
38	3.8	129.2	50.9
39	3.9	132.6	52.3
40	4.0	136.0	53.6
41	4.1	139.4	54.9
42	4.2	142.8	56.3
43	4.3	146.2	57.6
44	4.4	149.6	59.0
45	4.5	153.0	60.3
46	4.6	156.4	61.6
47	4.7	159.8	63.0
48	4.8	163.2	64.3
49	4.9	166.6	65.7
50	5.0	170.0	67.0
51	5.1	173.4	68.3
52	5.2	176.8	69.7
53	5.3	180.2	71.0

Delay Number	Time Difference (ms)	Distance (cm)	Distance (inch)
54	5.4	183.6	72.4
55	5.5	187.0	73.7
56	5.6	190.4	75.0
57	5.7	193.8	76.4
58	5.8	197.2	77.7
59	5.9	200.6	79.1
60	6.0	204.0	80.4
61	6.1	207.4	81.7
62	6.2	210.8	83.1
63	6.3	214.2	84.4
64	6.4	217.6	85.8
65	6.5	221.0	87.1
66	6.6	224.4	88.4
67	6.7	227.8	89.8
68	6.8	231.2	91.1
69	6.9	234.6	92.5
70	7.0	238.0	93.8
71	7.1	241.4	95.1
72	7.2	244.8	96.5
73	7.3	248.2	97.8
74	7.4	251.6	99.2
75	7.5	255.0	100.5
76	7.6	258.4	101.8
77	7.7	261.8	103.2
78	7.8	265.2	104.5
79	7.9	268.6	105.9
80	8.0	272.0	107.2
81	8.1	275.4	108.5
82	8.2	278.8	109.9
83	8.3	282.2	111.2
84	8.4	285.6	112.6
85	8.5	289.0	113.9
86	8.6	292.4	115.2
87	8.7	295.8	116.6
88	8.8	299.2	117.9
89	8.9	302.6	119.3
90	9.0	306.0	120.6
91	9.1	309.4	121.9
92	9.2	312.8	123.3
93	9.3	316.2	124.6
94	9.4	319.6	126.0
95	9.5	323.0	127.3
96	9.6	326.4	128.6
97	9.7	329.8	130.0
98	9.8	333.2	131.3
99	9.9	336.6	132.7

## About the Crossover

### Crossover (X-OVER):

This unit is equipped with an active crossover. The crossover limits the frequencies delivered to the outputs. Each channel is controlled independently. Thus, each speaker pair can be driven by the frequencies for which they have been optimally designed. The crossover adjusts the HPF (high pass filter) or LPF (low pass filter) of each band, and also the slope (how fast the filter rolls off the highs or lows).

Adjustments should be made according to the reproduction characteristics of the speakers. Depending on the speakers, a passive network may not be necessary. If you are unsure about this point, consult your authorized Alpine dealer.

### 4.2ch (FRONT/REAR/SUBW.) mode

	Cut-off frequency (1/3 octave steps)		Slope		Level
	HPF	LPF	HPF	LPF	
Low range speaker	---	20 Hz - 200 Hz	---	FLAT, 6, 12, 18, 24 dB/oct.	0 to -12 dB
Rear high range speaker	20 Hz - 200 Hz	---	FLAT, 6, 12, 18, 24 dB/oct.	---	0 to -12 dB
Front high range speaker	20 Hz - 200 Hz	---	FLAT, 6, 12, 18, 24 dB/oct.	---	0 to -12 dB

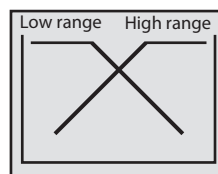

(Different from actual display)

### 2.2ch (3WAY) mode

	Cut-off frequency (1/3 octave steps)		Slope		Level
	HPF	LPF	HPF	LPF	
Low range speaker	---	20 Hz - 200 Hz	---	FLAT, 6, 12, 18, 24 dB/oct.	0 to -12 dB
Mid range speaker	20 Hz - 200 Hz	20 Hz - 20 kHz	FLAT, 6, 12, 18, 24 dB/oct.	FLAT, 6, 12, 18, 24 dB/oct.	0 to -12 dB
High range speaker	1 kHz - 20 kHz, (20 Hz ~ 20 kHz)*	---	FLAT* 6, 12, 18, 24 dB/oct.	---	0 to -12 dB

\* Only when TW Setup is set to USER'S (refer to "Setting the Response Slope for the High Range Speaker (TW Setup)" on page 37).

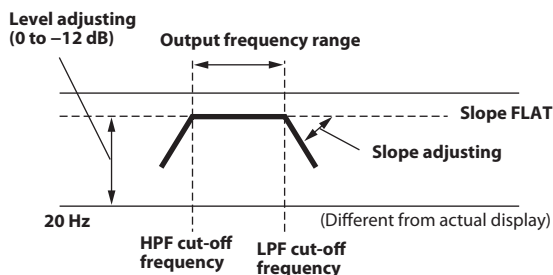
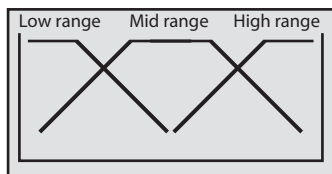

#### Notes

- **HPF (high pass filter):** Cuts the lower frequencies and allows the higher frequencies to pass.
  - **LPF (low pass filter):** Cuts the higher frequencies and allows the lower frequencies to pass.
  - **Slope:** The level change (in dB) for a frequency change of one octave.
  - The higher the slope value, the steeper the slope becomes.
  - Adjust the slope to FLAT to bypass the HP or LP filters.
  - Do not use a tweeter without the HPF on or set to a low frequency, as it may cause damage to the speaker due to the low frequency content.
  - You cannot adjust the crossover frequency higher than the HPF or lower than the LPF.
  - Adjustment should be made according to the recommended crossover frequency of the connected speakers. Determining the recommended crossover frequency of the speakers. Adjusting to a frequency range outside that recommended may cause damage to the speakers. For the recommended crossover frequencies of Alpine speakers, refer to the respective Owner's Manual.
- We are not responsible for damage or malfunction of speakers caused by using the crossover outside the recommended value.

## Changer (optional)

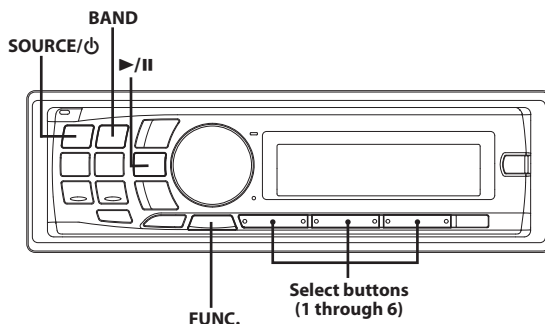

## Controlling CD Changer (optional)

An optional 6-disc or 12-disc CD Changer may be connected to this unit if it is Ai-NET compatible. With a CD Changer connected to the Ai-NET input of this unit, the CD Changer will be controllable from this unit.

Using the KCA-400C (Multi-Changer Switching device) or the KCA-410C (Versatile Link Terminal) multiple changers can be controlled by this unit.

Refer to "Multi-Changer Selection (optional)" on page 43 for selecting the CD Changers.

#### Notes

- The controls on this unit for CD Changer operation are operative only when a CD Changer is connected.
- The DVD changer (optional) is controllable from this unit as well as the CD changer.
- Depending on the connected DVD Changer, some functions may not be available.

### 1 Press SOURCE/⏻ to activate the CHANGER mode.

The display shows the disc number and track number.

#### Notes

- The source indicator varies depending on the connected source.
- Press **BAND** to switch the Disc mode in the Changer mode.

### 2 Press FUNC. to activate Disc Select mode.

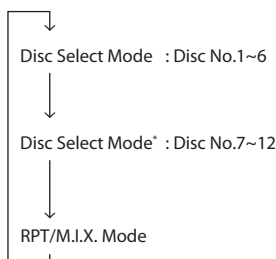

\* When a 12-disc CD changer is connected.

### 3 Press the disc select buttons (1 through 6) corresponding to one of the discs loaded in the CD Changer.

The selected disc number appears in the display and CD/MP3 playback starts.

## Note

- After selecting the desired disc, you can operate in the same way as for the CD player of this unit. For details, see the CD/MP3/WMA/AAC section.

## Playing MP3 Files with the CD Changer (optional)

If you connect a changer compatible with MP3, you can play CD-ROMs, CD-Rs, and CD-RWs containing MP3 files on this unit.

- Press **SOURCE** /  to switch to the MP3 Changer mode.
- Press any one of the disc select buttons (1 through 6) corresponding to one of the discs loaded in the CD Changer.
- To pause playback, press **▶/||**.  
Pressing **▶/||** again will resume playback.

## Notes

- The unit can play discs containing both audio data and MP3 data.
- For operating MP3 with an MP3 compatible CD Changer, refer to "CD/MP3/WMA/AAC" on page 12.

## Multi-Changer Selection (optional)

Alpine's Ai-NET system will support up to 6 CD Changers. When operating two or more changers, the KCA-400C (Multi-Changer Switching device) must be used. If you use 1 Switching device, you can connect up to 4 CD Changers. If you use 2 Switching devices, you can connect up to 6 CD Changers. When using KCA-410C (Versatile Link Terminal), you can connect two changers and two external outputs (AUX).

- Press **SOURCE** /  on this unit to activate the CD Changer mode.  
Alternatively, press **SOURCE** on the remote control (RUE-4202) to activate the CD Changer mode.

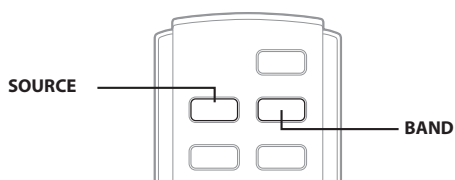

- Press **BAND** to activate the CD Changer Selection mode.  
The CD Changer Selection mode remains active for several seconds.
- Press **BAND** until the desired CD Changer indicator appears on the display.

## Notes

- If the selected CD Changer is not connected, the display will show "NO CHANGER-(No.)".
- To operate the selected changer, refer to "CD/MP3/WMA/AAC" on page 12.
- For further details about the external input (AUX) when using KCA-410C, refer to "Setting the AUX Mode (V-Link)" on page 22.

# Remote Control

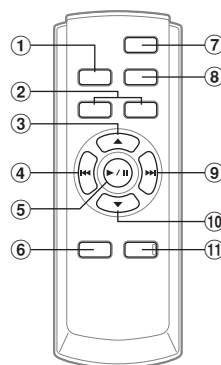

## Controls on Remote Control

### ① Source Button

Press this button to select the audio source.

### ② Volume Adjustment Buttons

To increase the volume level:

Press the  button





To decrease the volume level:

Press the  button

### ③ ▲ Button

#### Radio mode:

Pressing this button will select, in ascending order, stations programmed into the radio's presets as shown below.

 →  ...  → 

#### CD Changer mode:

DISC Select (UP) button.

Press this button to select a disc in ascending order.

#### MP3/WMA/AAC mode:

Folder Select (UP) button.

Press this button to select the folder.

#### MP3 compatible CD changer mode:

Folder Select (UP) / DISC Select (UP) button. Press this button to select a folder in ascending order. Press and hold this button to select a disc in ascending order.

#### iPod mode:

Switches Playlist/Artist/Album/Genre/Composer.

### ④ ◀◀ DN Button

#### Radio mode:

SEEK (DN) Button.

#### CD/iPod mode:

Press this button to go back to the beginning of the current track.

### ⑤ ▶/|| Button

Press this button to switch between the Play and Pause modes for CD.

### ⑥ Audio Processor Button

Each press of the button changes the audio processor mode.

For details, refer to "Operating the Audio Processor" as shown below. Press the button to activate the external audio processor mode when the external audio processor is connected.\*

\* For the operation of external audio processor, refer to the Owner's Manual of the external audio processor you purchased. When the

IMPRINT audio processor (PXA-H100) (sold separately) is connected, refer to "IMPRINT Operation (optional)" on page 35.

**⑦ Power Button**

Press this button to turn the power on/off.

**⑧ Band Button**

**Radio mode:**

BAND Button.  
Press this button and the band will change.

**Changer mode:**

To switch the changer.

**⑨ ►► UP Button**

**Radio mode:**

SEEK (UP) button.

**CD/iPod mode:**

Press this button to advance to the beginning of the next track.

**⑩ ▼ Button**

**Radio mode:**

Pressing this button will select, in descending order, stations programed into the radio's presets as shown below.

6 → 5 ... 1 → 6

**CD Changer mode:**

DISC Select (DN) button.  
Press this button to select a disc in descending order.

**MP3/WMA/AAC mode:**

Folder Select (DN) button.  
Press this button to select the folder.

**MP3 compatible CD changer mode:**

Folder Select (DN) / DISC Select (DN) button.  
Press this button to select a folder in descending order.  
Press and hold this button to select a disc in descending order.

**iPod mode:**

Switches Playlist/Artist/Album/Genre/Composer.

**⑪ Mute Button**

Press this button to lower the volume by 20 dB instantly.  
Press this button again to cancel.

## Operating the Audio Processor

**1 Press A.PROC to select the mode.**

Normal mode → Time Correction → X-OVER → Normal mode

**2 Press ▲ or ▼ to select the item.**

**Time Correction mode/Crossover (X-OVER) mode:**

Select from MEMORY 1 through 6.

## Battery Replacement

Applicable battery: Use two "AAA" sized dry batteries or equivalent.

**1 Opening the battery cover**

Slide out the battery cover while firmly pressing in the direction of the arrow.

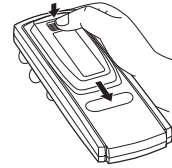

**2 Replacing the battery**

Insert the batteries, observing the polarities as illustrated.

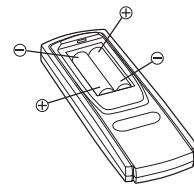

**3 Closing the cover**

Slide the cover as illustrated until a click is heard.

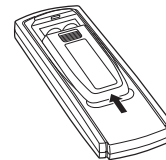

## Controllable With Remote Control

Point the remote control transmitter at the remote control sensor.

Remote control sensor

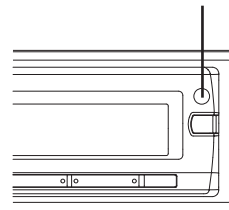

## Connectable to Remote Control Interface Box

This unit may be controlled from the vehicle's audio controls. An optional Alpine Remote Control Interface Box must be used. For details, contact your Alpine dealer.

# Information

## In Case of Difficulty

If you encounter a problem, turn the power off, then on again. If the unit is still not functioning normally, review the items in the following checklist. This guide will help you isolate the problem if the unit is at fault. Otherwise, make sure the rest of your system is properly connected or consult your authorized Alpine dealer.

### Basic

#### No function or display.

- Vehicle's ignition is off.
  - If connected following instructions, the unit will not operate with the vehicle's ignition off.
- Improper power lead (Red) and battery lead (Yellow) connections.
  - Check power lead and battery lead connections.
- Blown fuse.
  - Check the fuse of the unit; replace with the proper value if necessary.
- Internal micro-computer malfunctioned due to interference noise etc.
  - Press the RESET switch with a ballpoint pen or other pointed article.

### Radio

#### Unable to receive stations.

- No antenna or open connection in cable.
  - Make sure the antenna is properly connected; replace the antenna or cable if necessary.

#### Unable to tune stations in the seek mode.

- You are in a weak signal area.
  - Make sure the tuner is in the DX mode.
- If the area you are in is a primary signal area, the antenna may not be grounded and connected properly.
  - Check your antenna connections; make sure the antenna is properly grounded at its mounting location.
- The antenna may not be the proper length.
  - Make sure the antenna is fully extended; if broken, replace the antenna with a new one.

#### Broadcast is noisy.

- The antenna is not the proper length.
  - Extend the antenna fully; replace it if it is broken.
- The antenna is poorly grounded.
  - Make sure the antenna is grounded properly at its mounting location.

### CD

#### CD Player not functioning.

- Out of operating temperature range +50°C (+120°F) for CD.
  - Allow the vehicle's interior (or trunk) temperature to cool.

#### CD playback sound is wavering.

- Moisture condensation in the CD Module.
  - Allow enough time for the condensation to evaporate (about 1 hour).

#### CD insertion not possible.

- A CD is already in the CD player.
  - Eject the CD and remove it.

- The CD is being improperly inserted.
  - Make sure the CD is being inserted following instructions in the CD Player Operation section.

#### Unable to fast forward or backward the CD.

- The CD has been damaged.
  - Eject the CD and discard it; using a damaged CD in your unit can cause damage to the mechanism.

#### CD playback sound skips due to vibration.

- Improper mounting of the unit.
  - Securely re-mount the unit.
- The disc is very dirty.
  - Clean the disc.
- The disc has scratches.
  - Change the disc.
- The pick-up lens is dirty.
  - Do not use a commercially available lens cleaner disc. Consult your nearest Alpine dealer.

#### CD playback sound skips without vibration.

- The disc is dirty or scratched.
  - Clean the disc; damaged disc should be replaced.

#### Error displays (built-in CD player only).

- Mechanical error.
  - Press . After the error indication disappears, insert the disc again. If the above-mentioned solution does not solve the problem, consult your nearest Alpine dealer.

#### CD-R/CD-RW playback not possible.

- Close session (finalization) has not been performed.
  - Perform finalization and attempt playback again.

### MP3/WMA/AAC

#### MP3, WMA or AAC is not played back.

- Writing error occurred. The MP3/WMA/AAC format is not compatible.
  - Make sure the MP3/WMA/AAC has been written in a supported format. Refer to "About MP3/WMA/AAC" on page 14, then rewrite in the format supported by this device.

### Audio

#### The sound is not output from the speakers.

- There is no signal output from the internal amplifier.
  - Power IC is switched to "ON" (refer to "Connecting to an External Amplifier" on page 22).

### iPod

#### iPod does not play and no sound is output.





- The iPod has not been recognized.
  - Reset this unit and the iPod. Refer to "Initial System Start-Up" on page 8. To reset the iPod, refer to the Owner's Manual of the iPod.

### Indication for CD Player

#### No Disc

- No CD is inserted.
  - Insert a CD.
- Although a disc is inserted, "No Disc" is displayed and the unit does not start to play or eject the disc.
  - Remove the disc by following these steps:
    - Press the  button again for at least 2 seconds.
  - If the disc still does not eject, consult your Alpine dealer.

## Error

- Mechanism error.
  - 1 **Press the  button and eject the CD.**  
If not ejecting, consult your Alpine dealer.
  - 2 **When the error indication remains after ejecting, press the  button again.**  
If the error indication still does not turn off after pressing the  button for a few times, consult your Alpine dealer.
- When "Error" is displayed:  
If the disc cannot be ejected by pressing , press the RESET switch (refer to "Initial System Start-Up" on page 8) and press  again.  
If the disc still cannot be ejected, consult your Alpine dealer.

## PROTECT

- A copy-protected WMA file was played back.
  - You can only play back non-copy-protected files.

## UNSUPPORTED

- A sampling rate/bit rate not supported by the unit is used.
  - Use a sampling rate/bit rate that is supported by the unit.

## Indication for CD Changer

### High Temperature

- Protective circuit is activated due to high temperature.
  - The indication will disappear when the temperature returns to normal operating range.

### Error 01

- Malfunction in the CD Changer.
  - Consult your Alpine dealer. Press the magazine eject button and pull out the magazine.  
Check the indication. Insert the magazine again.  
If the magazine cannot be pulled out, consult your Alpine dealer.
- Magazine ejection not possible.
  - Press the magazine eject button. If the magazine does not eject, consult your Alpine dealer.

### Error 02

- A disc is left inside the CD Changer.
  - Press the eject button to activate the eject function. When the CD Changer finishes the eject function, insert an empty CD magazine into the CD Changer to receive the disc left inside the CD Changer.

### No Magazine

- No magazine is loaded into the CD Changer.
  - Insert a magazine.

### No Disc

- No indicated disc.
  - Choose another disc.

## Indication for SAT Receiver Mode

### Check XM Tuner

(XM mode)

- MiniTuner missing/disconnected or no communication between the unit and XM Radio.
  - Check the XM Tuner.

### Check Antenna

(XM mode)

### Antenna Error

(SIRIUS mode)

- The XM or SIRIUS antenna is not connected to the XM or SIRIUS radio module.
  - Check whether the XM or SIRIUS antenna cable is attached securely to the XM or SIRIUS radio module.

### No Signal

(XM mode)

### Acquiring Signal

(SIRIUS mode)

- XM or SIRIUS signal is too weak at the current location.
  - Wait until the car reaches a location with a stronger signal.

### Loading

(XM mode)

- Radio is acquiring audio or program information.
  - Wait until the radio has received the information.

### Channel Off Air

(XM mode)

- The channel currently selected has stopped broadcasting.
  - Select another channel.

### Chan Unavailable

(XM mode)

### Invalid Channel

(SIRIUS mode)

- The user has selected a channel number that does not exist.
  - The unit will revert back to the previously selected channel.

### Ch Unauthorized

(XM mode)

- The user has selected a channel number that is not authorized.
  - The unit will revert to the previous selected channel or to channel 1 automatically.

### FW Updating

(SIRIUS mode)

- Radio's firmware is being updated. During firmware update, audio will be muted until update is completed.
  - Wait until the update is completed. After completion, automatically re-tune to previous channel.



## SUB Updating

(SIRIUS mode)

- The subscribed program is being updated. During update, audio will be muted until update is completed.
  - Wait until the update is completed. After completion, follow the indication “SUB Updated Press Any Key” to press any key on the unit to continue, the unit re-tune to previous channel.

## Updating Channels

(SIRIUS mode)

- The Receiver is updating the SIRIUS channel line up. During update audio will be muted until update is completed.
  - Wait until the channel update is completed. After completion, the unit automatically re-tune to previous channel.

## Indication for USB Memory/Portable audio player

### Error 01

- Database error or decoder error.
  - You can solve the problem by switching the source.

### Error 02

- Communication error or boot error, etc.
  - You can solve the problem by reconnecting the USB Memory/Portable audio player or changing source.

### Error 03

- The Portable audio player is not verified.
  - You can solve the problem by reconnecting the Portable audio player.

### Current Error

- Abnormal current is run to the USB connector device.
  - You can solve the problem by switching the source.

### Device Error

- A USB device/Portable audio player that is not supported by the unit is connected.
  - Connect a USB device/Portable audio player that is supported by the unit.

### No USB Unit

- A USB Memory/Portable audio player is not connected.
  - Make sure the USB Memory device/Portable audio player is correctly connected and the cable is not excessively bent.

### NO FILE

- No song (file) is stored in the USB Memory/Portable audio player.
  - Connect the USB Memory device/Portable audio player after storing songs (files).

## UNSUPPORTED

- A sampling rate/bit rate not supported by the unit is used.
  - Use a sampling rate/bit rate that is supported by the unit.

## PROTECT

- A copy-protected WMA file was played back.
  - You can only play back non-copy-protected files.

## Indication for iPhone/iPod Mode

### No USB Unit

- The iPhone/iPod is not connected.
  - Make sure the iPhone/iPod is correctly connected (refer to “Connections” on page 52).  
Make sure the cable is not bent excessively.

### NO SONG

- There are no songs in the iPhone/iPod.
  - Download songs to the iPhone/iPod and connect to this unit.

### Error 01

- Database error or decoder error.
  - You can solve the problem by switching the source.

### Error 02

- Communication error or boot error, etc.
  - You can solve the problem by reconnecting the iPhone/iPod or changing source.

### Error 03

- The iPhone/iPod is not verified.
  - You can solve the problem by reconnecting the iPhone/iPod.

### Current Error

- Abnormal current is run to the USB connector device.
  - You can solve the problem by switching the source.

### Device Error

- A USB device that is not supported by the unit is connected.
  - Connect a USB device that is supported by the unit.

---

## Specifications

---

### FM TUNER SECTION

Tuning Range	87.7-107.9 MHz
Mono Usable Sensitivity	9.3 dBf (0.8 $\mu$ V/75 ohms)
50 dB Quieting Sensitivity	13.5 dBf (1.3 $\mu$ V/75 ohms)
Alternate Channel Selectivity	80 dB
Signal-to-Noise Ratio	65 dB
Stereo Separation	35 dB
Capture Ratio	2.0 dB

### AM TUNER SECTION

Tuning Range	530-1,710 kHz
Sensitivity (IEC Standard)	22.5 $\mu$ V/27 dB

### CD PLAYER SECTION

Frequency Response	5-20,000 Hz ( $\pm$ 1 dB)
Wow & Flutter (% WRMS)	Below measurable limits
Total Harmonic Distortion	0.008% (at 1 kHz)
Dynamic Range	95 dB (at 1 kHz)
Signal-to-Noise Ratio	105 dB
Channel Separation	85 dB (at 1 kHz)

### USB SECTION

USB requirements	USB 1.1/2.0
Max. Power Consumption	500 mA
USB Class	Mass Storage
File System	FAT 12/16/32
MP3 Decoding	MPEG-1/2 AUDIO Layer-3
WMA Decoding	Windows Media™ Audio
AAC Decoding	AAC-LC format “.m4a” file
Number of Channels	2-Channel (Stereo)
Frequency Response*	5-20,000 Hz ( $\pm$ 1 dB)
Total Harmonic Distortion	0.008% (at 1 kHz)
Dynamic Range	95 dB (at 1 kHz)
Signal-to-Noise Ratio	105 dB
Channel Separation	85 dB (at 1 kHz)

\* Frequency response may differ depending on the encoder software/bit rate.

### PICKUP

Wave length	795 nm
Laser power	CLASS I

### REMOTE CONTROL

Battery Type	AAA batteries (2 pcs.)
Width	42 mm (1-21/32")
Height	121 mm (4-25/32")
Depth	23 mm (29/32")
Weight	50 g (1.8 oz)

### GENERAL

Power Requirement	14.4 V DC (11-16 V allowable)
Power Output	18 W RMS $\times$ 4*
Maximum Pre-Output Voltage	4 V/10 k ohms
Weight	1.6 kg (3 lbs. 8 oz)

\* Primary amplifier ratings per CEA-2006 Standard

- Power output: measured at 4 Ohms and  $\leq$  1% THD+N
- S/N: 80 dBA (reference: 1 W into 4 Ohms)

### CHASSIS SIZE

Width	178 mm (7")
Height	50 mm (2")
Depth	160 mm (6-1/4")

### NOSEPIECE SIZE

Width	170 mm (6-3/4")
Height	46 mm (1-13/16")
Depth	23 mm (15/16")

### Note

- Due to continuous product improvement, specifications and design are subject to change without notice.

# Installation and Connections

Before installing or connecting the unit, please read the following and refer to “Operating Instructions” on page 4 for proper use.

## Warning

### **MAKE THE CORRECT CONNECTIONS.**

Failure to make the proper connections may result in fire or product damage.

### **USE ONLY IN CARS WITH A 12 VOLT NEGATIVE GROUND.**

(Check with your dealer if you are not sure.) Failure to do so may result in fire, etc.

### **BEFORE WIRING, DISCONNECT THE CABLE FROM THE NEGATIVE BATTERY TERMINAL.**

Failure to do so may result in electric shock or injury due to electrical shorts.

### **DO NOT SPLICE INTO ELECTRICAL CABLES.**

Never cut away cable insulation to supply power to other equipment. Doing so will exceed the current carrying capacity of the wire and result in fire or electric shock.

### **DO NOT DAMAGE PIPE OR WIRING WHEN DRILLING HOLES.**

When drilling holes in the chassis for installation, take precautions so as not to contact, damage or obstruct pipes, fuel lines, tanks or electrical wiring. Failure to take such precautions may result in fire.

### **DO NOT USE BOLTS OR NUTS IN THE BRAKE OR STEERING SYSTEMS TO MAKE GROUND CONNECTIONS.**

Bolts or nuts used for the brake or steering systems (or any other safety-related system), or tanks should NEVER be used for installations or ground connections. Using such parts could disable control of the vehicle and cause fire etc.

### **KEEP SMALL OBJECTS SUCH AS BATTERIES OUT OF THE REACH OF CHILDREN.**

Swallowing them may result in serious injury. If swallowed, consult a physician immediately.

### **DO NOT INSTALL IN LOCATIONS WHICH MIGHT HINDER VEHICLE OPERATION, SUCH AS THE STEERING WHEEL OR GEARSHIFT.**

Doing so may obstruct forward vision or hamper movement etc. and results in serious accident.

## Caution

### **HAVE THE WIRING AND INSTALLATION DONE BY EXPERTS.**

The wiring and installation of this unit requires special technical skill and experience. To ensure safety, always contact the dealer where you purchased this product to have the work done.

### **USE SPECIFIED ACCESSORY PARTS AND INSTALL THEM SECURELY.**

Be sure to use only the specified accessory parts. Use of other than designated parts may damage this unit internally or may not

securely install the unit in place. This may cause parts to become loose resulting in hazards or product failure.

### **ARRANGE THE WIRING SO IT IS NOT CRIMPED OR PINCHED BY A SHARP METAL EDGE.**

Route the cables and wiring away from moving parts (like the seat rails) or sharp or pointed edges. This will prevent crimping and damage to the wiring. If wiring passes through a hole in metal, use a rubber grommet to prevent the wire's insulation from being cut by the metal edge of the hole.

### **DO NOT INSTALL IN LOCATIONS WITH HIGH MOISTURE OR DUST.**

Avoid installing the unit in locations with high incidence of moisture or dust. Moisture or dust that penetrates into this unit may result in product failure.

## Precautions

- Be sure to disconnect the cable from the (-) battery post before installing your CDA-117. This will reduce any chance of damage to the unit in case of a short-circuit.
- Be sure to connect the color coded leads according to the diagram. Incorrect connections may cause the unit to malfunction or damage to the vehicle's electrical system.
- When making connections to the vehicle's electrical system, be aware of the factory installed components (e.g. on-board computer). Do not tap into these leads to provide power for this unit. When connecting the CDA-117 to the fuse box, make sure the fuse for the intended circuit of the CDA-117 has the appropriate amperage. Failure to do so may result in damage to the unit and/or the vehicle. When in doubt, consult your Alpine dealer.
- The CDA-117 uses female RCA-type jacks for connection to other units (e.g. amplifier) having RCA connectors. You may need an adaptor to connect other units. If so, please contact your authorized Alpine dealer for assistance.
- Be sure to connect the speaker (-) leads to the speaker (-) terminal. Never connect left and right channel speaker cables to each other or to the vehicle body.

### **IMPORTANT**

Please record the serial number of your unit in the space provided below and keep it as a permanent record. The serial number or the engraved serial number is located on the bottom of the unit.

SERIAL NUMBER: [	]
INSTALLATION DATE: [	]
INSTALLATION TECHNICIAN: [	]
PLACE OF PURCHASE: [	]

# Installation

## Caution

When you install this unit in your car, do not remove the detachable front panel. If the detachable front panel is removed during installation, you might press too hard and warp the metal plate that holds it in place. The main unit must be mounted within 35 degrees of the horizontal plane, back to front.

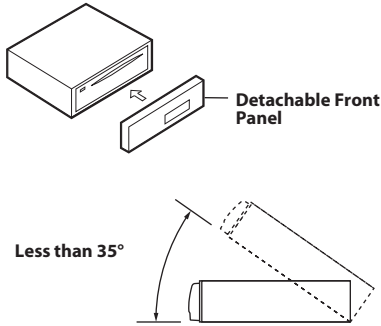

- 1 Remove the mounting sleeve from the main unit (refer to "Removal" on page 50).

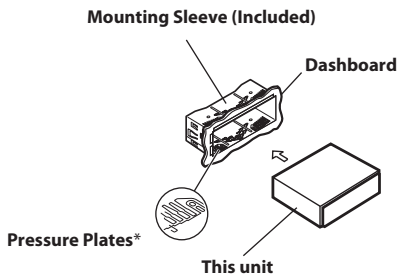

\* If the installed mounting sleeve is loose in the dashboard, the pressure plates may be bent slightly to remedy the problem.

- 2 Reinforce the head unit with the metal mounting strap (not supplied). Secure the ground lead of the unit to a clean metal spot using a screw (\*) already attached to the vehicle's chassis.

Connect each input lead coming from an amplifier or equalizer to the corresponding output lead coming from the left rear of

the CDA-117. Connect all other leads of the CDA-117 according to details described in the CONNECTIONS section.

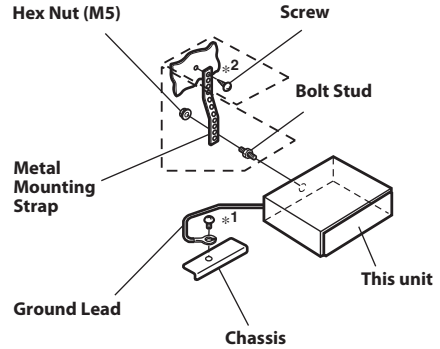

### Note

- For the screw marked <sup>\*2</sup>, use an appropriate screw for the chosen mounting location.

- 3 Slide the CDA-117 into the dashboard until it clicks. This ensures that the unit is properly locked and will not accidentally come out from the dashboard.

## Removal

- 1 Remove the detachable front panel.
- 2 Insert the bracket keys into the unit, along the guides on either side. The unit can now be removed from the mounting sleeve.

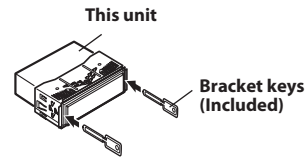

- 3 Pull the unit out, keeping it unlocked as you do so.

### JAPANESE CAR

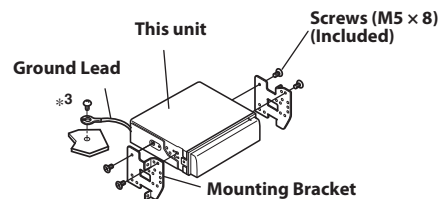
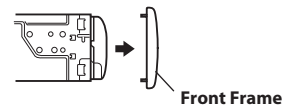

### Note

- Secure the ground lead of the unit to a clean metal spot using a screw (<sup>\*3</sup>) already attached to the vehicle's chassis.

## iPhone/iPod Connection (sold separately)

Connect USB cable to an iPhone/iPod with Interface cable for iPod.

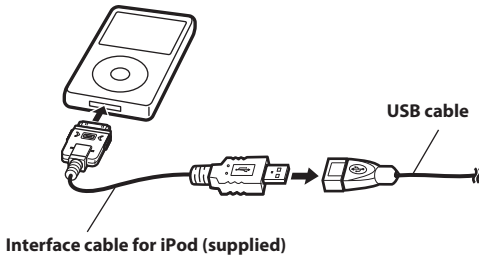

## Remove the iPhone/iPod

Remove the iPhone/iPod from Interface cable for iPod.

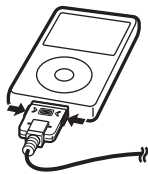

### Notes

- After changing the unit to a source other than the USB iPod, remove the iPhone/iPod. If the iPhone/iPod is removed in the USB iPod mode, data may cause damage.
- If sound is not output or the iPhone/iPod is not recognized even when the iPhone/iPod is connected, remove the iPhone/iPod once, then connect it again, or reset the iPod.
- Do not leave the iPhone/iPod in a vehicle for a long time. Heat and humidity may damage the iPhone/iPod and you may not be able to play it again.

## USB Memory Connection (sold separately)

### Connect USB Memory

Connect the USB cable to the USB connector of the unit, and then secure the connection using the lock case supplied with USB cable as shown below.

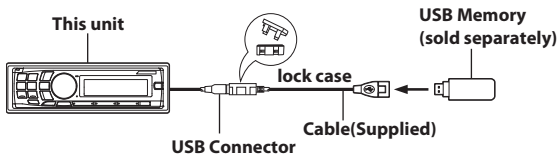

### Remove USB Memory

Pull out USB Memory squarely from the USB cable.

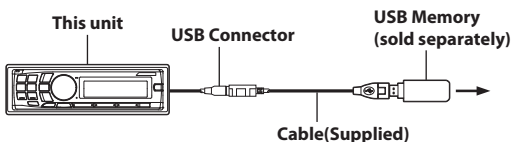

### Notes

- When removing USB Memory, pull it out straight.
- If sound is not output or USB Memory is not recognized even when USB Memory is connected, remove USB Memory once, then connect it again.
- Change to a source other than the USB Memory mode, then remove the USB Memory. If the USB Memory is removed in the USB Memory mode, data may be damaged.
- Route the USB cable away from other cables.

# Connections

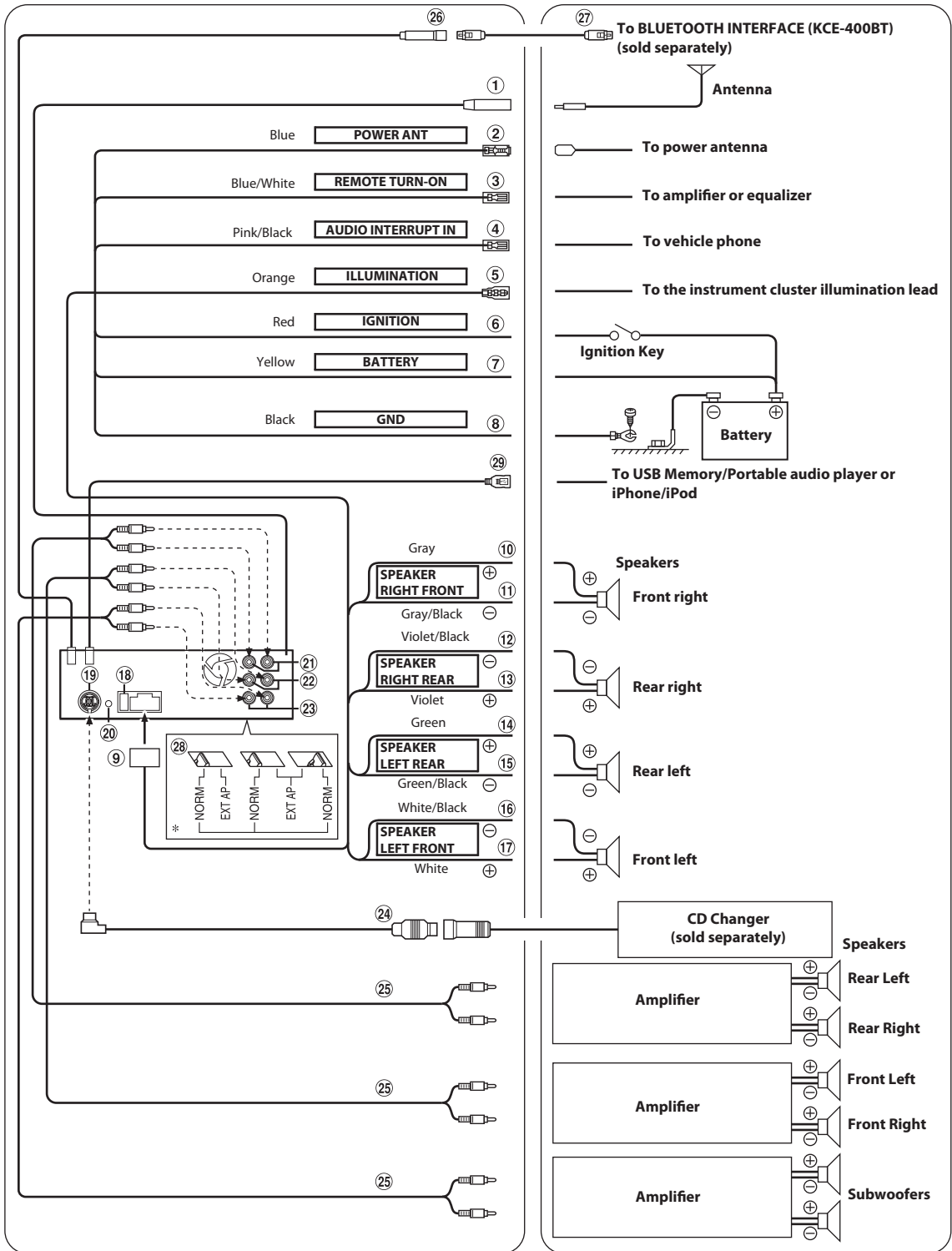

\* The system switch is located on the bottom of the unit.

① **Antenna Receptacle**

② **Power Antenna Lead (Blue)**

Connect this lead to the +B terminal of your power antenna, if applicable.

**Note**

- This lead should be used only for controlling the vehicle's power antenna. Do not use this lead to turn on an amplifier, or a signal processor, etc.

③ **Remote Turn-On Lead (Blue/White)**

Connect this lead to the remote turn-on lead of your amplifier or signal processor.

④ **Audio Interrupt In Lead (Pink/Black)**

Connect this lead to the Audio interface output of a cellular phone which provides ground shorting when a call is received.

⑤ **Illumination Lead (Orange)**

This lead may be connected to the vehicle's instrument cluster illumination lead. This will allow the backlighting of the CDA-117 to dim whenever the vehicle's lights are turned on.

⑥ **Switched Power Lead (Ignition) (Red)**

Connect this lead to an open terminal on the vehicle's fuse box or another unused power source which provides (+)12V only when the ignition is turned on or in the accessory position.

⑦ **Battery Lead (Yellow)**

Connect this lead to the positive (+) post of the vehicle's battery.

⑧ **Ground Lead (Black)**

Connect this lead to a good chassis ground on the vehicle. Make sure the connection is made to bare metal and is securely fastened using the sheet metal screw provided.

⑨ **Power Supply Connector**

⑩ **Right Front (+) Speaker Output Lead (Gray)**

⑪ **Right Front (-) Speaker Output Lead (Gray/Black)**

⑫ **Right Rear (-) Speaker Output Lead (Violet/Black)**

⑬ **Right Rear (+) Speaker Output Lead (Violet)**

⑭ **Left Rear (+) Speaker Output Lead (Green)**

⑮ **Left Rear (-) Speaker Output Lead (Green/Black)**

⑯ **Left Front (-) Speaker Output Lead (White/Black)**

⑰ **Left Front (+) Speaker Output Lead (White)**

⑱ **Fuse Holder (10A)**

⑲ **Ai-NET Connector**

Connect this to the output or input connector of other product (CD changer, IMPRINT audio processor, Equalizer, etc.) equipped with Ai-NET.

**Notes**

- Interface adapter for iPod (KCA-420i) is not recommended for use with this product.
- You can input TV/video sound by connecting an optional Ai-NET/ RCA Interface cable (KCA-121B) to this component.
- Be sure to set "Setting the Connected Head Unit (MODEL SETUP)" to "CD CHG", when the DHA-S690 is connected.

⑳ **Steering Remote Control Interface Connector**

To steering Remote control interface box.

㉑ **Rear Output/Input RCA Connectors**

It can be used as Rear Output or Input RCA Connectors. RED is right and WHITE is left.

㉒ **Front Output/Input RCA Connectors**

It can be used as Front Output or Input RCA Connectors. RED is right and WHITE is left.

㉓ **Subwoofer RCA Connectors**

RED is right and WHITE is left.

㉔ **Ai-NET Cable (Included with CD Changer)**

㉕ **RCA Extension Cable (sold separately)**

㉖ **BLUETOOTH interface connector (Blue)**

Connect this to an optional BLUETOOTH INTERFACE (KCE-400BT). To use a hands-free mobile phone, an optional BLUETOOTH INTERFACE

(KCE-400BT) connection is required. For details on connection, refer to the Owner's Manual of the BLUETOOTH INTERFACE (KCE-400BT). You can also connect this to an external device (such as a portable player) by using Conversion cable (KCE-237B) for building up the AUX IN (sold separately).

**Note**

- Refer to "Setting the AUX+ Setup Mode" on page 22.
- AUX+ ON :  
When the external device is connected.
- AUX+ OFF :  
When set to OFF, AUX+ source cannot be selected.

㉗ **KCE-400BT Connection Cable (Included with KCE-400BT)**

㉘ **System Switch**

When connecting a processor or divider using Ai-NET, place the three switches in the EXT AP position. When no device is connected, leave the switch in the NORM position.

**Notes**

- Do not make the three switches to different settings.
- Be sure to turn the power off to the unit before changing the switch position.

㉙ **USB Connector**

Connect this to an USB Memory/Portable audio player or to an iPhone/iPod. To use an iPhone/iPod, Interface cable for iPod connection is required.

**Notes**

- Use the supplied USB cable. If a USB cable other than the supplied is used, correct performance cannot be guaranteed.
- Route the USB cable away from other cables.

**To prevent external noise from entering the audio system.**

- Locate the unit and route the leads at least 10 cm away from the car harness.
- Keep the battery power leads as far away from other leads as possible.
- Connect the ground lead securely to a bare metal spot (remove any paint, dirt or grease if necessary) of the car chassis.
- If you add an optional noise suppressor, connect it as far away from the unit as possible. Your Alpine dealer carries various noise suppressors, contact them for further information.
- Your Alpine dealer knows best about noise prevention measures so consult your dealer for further information.



## LIMITED WARRANTY

ALPINE ELECTRONICS OF AMERICA, INC. AND ALPINE OF CANADA INC. ("Alpine"), are dedicated to quality craftsmanship and are pleased to offer this Warranty. We suggest that you read it thoroughly. Should you have any questions, please contact your Dealer or contact Alpine at one of the telephone numbers listed below.

### ● PRODUCTS COVERED:

This Warranty covers Car Audio Products and Related Accessories ("the product"). Products purchased in the Canada are covered only in the Canada. Products purchased in the U.S.A. are covered only in the U.S.A.

### ● LENGTH OF WARRANTY:

This Warranty is in effect for one year from the date of the first consumer purchase.

### ● WHO IS COVERED:

This Warranty only covers the original purchaser of the product, who must reside in the United States, Puerto Rico or Canada.

### ● WHAT IS COVERED:

This Warranty covers defects in materials or workmanship (parts and labor) in the product.

### ● WHAT IS NOT COVERED:

This Warranty does not cover the following:

- ① Damage occurring during shipment of the product to Alpine for repair (claims must be presented to the carrier).
- ② Damage caused by accident or abuse, including burned voice coils caused by over-driving the speaker (amplifier level is turned up and driven into distortion or clipping). Speaker mechanical failure (e.g. punctures, tears or rips). Cracked or damaged LCD panels. Dropped or damaged hard drives.
- ③ Damage caused by negligence, misuse, improper operation or failure to follow instructions contained in the Owner's manual.
- ④ Damage caused by act of God, including without limitation, earthquake, fire, flood, storms or other acts of nature. Any cost or expense related to the removal or reinstallation of the product.
- ⑤ Service performed by an unauthorized person, company or association.
- ⑥ Any product which has the serial number defaced, altered or removed.
- ⑦ Any product which has been adjusted, altered or modified without Alpine's consent.
- ⑧ Any product not distributed by Alpine within the United States, Puerto Rico or Canada.
- ⑨ Any product not purchased from an Authorized Alpine Dealer.

### ● HOW TO OBTAIN WARRANTY SERVICE:

- ① You are responsible for delivery of the product to an Authorized Alpine Service Center or Alpine for repair and for payment of any initial shipping charges. Alpine will, at its option, repair or replace the product with a new or reconditioned product without charge. If the repairs are covered by the warranty, and if the product was shipped to an Authorized Alpine Service Center or Alpine, Alpine will pay the return shipping charges.
- ② You should provide a detailed description of the problem(s) for which service is required.

③ You must supply proof of your purchase of the product.

④ You must package the product securely to avoid damage during shipment. To prevent lost packages it is recommended to use a carrier that provides a tracking service.

### ● HOW WE LIMIT IMPLIED WARRANTIES:

ANY IMPLIED WARRANTIES INCLUDING FITNESS FOR USE AND MERCHANTABILITY ARE LIMITED IN DURATION TO THE PERIOD OF THE EXPRESS WARRANTY SET FORTH ABOVE AND NO PERSON IS AUTHORIZED TO ASSUME FOR ALPINE ANY OTHER LIABILITY IN CONNECTION WITH THE SALE OF THE PRODUCT.

### ● HOW WE EXCLUDE CERTAIN DAMAGES:

ALPINE EXPRESSLY DISCLAIMS LIABILITY FOR INCIDENTAL AND CONSEQUENTIAL DAMAGES CAUSED BY THE PRODUCT. THE TERM "INCIDENTAL DAMAGES" REFERS TO EXPENSES OF TRANSPORTING THE PRODUCT TO THE ALPINE SERVICE CENTER, LOSS OF THE ORIGINAL PURCHASER'S TIME, LOSS OF THE USE OF THE PRODUCT, BUS FARES, CAR RENTALS OR OTHERS COSTS RELATING TO THE CARE AND CUSTODY OF THE PRODUCT. THE TERM "CONSEQUENTIAL DAMAGES" REFERS TO THE COST OF REPAIRING OR REPLACING OTHER PROPERTY WHICH IS DAMAGED WHEN THIS PRODUCT DOES NOT WORK PROPERLY. THE REMEDIES PROVIDED UNDER THIS WARRANTY ARE EXCLUSIVE AND IN LIEU OF ALL OTHERS.

### ● HOW STATE/PROVINCIAL LAW RELATES TO THE WARRANTY:

This Warranty gives you specific legal rights, and you may also have other rights which vary from state to state and province to province. In addition, some states/provinces do not allow limitations on how long an implied warranty lasts, and some do not allow the exclusion or limitation of incidental or consequential damages. Accordingly, limitations as to these matters contained herein may not apply to you.

### ● IN CANADA ONLY:

This Warranty is not valid unless your Alpine car audio product has been installed in your vehicle by an Authorized Installation Center, and this warranty stamped upon installation by the installation center.

### ● HOW TO CONTACT CUSTOMER SERVICE:

Should the product require service, please call the following number for your nearest Authorized Alpine Service Center.

<b>CAR AUDIO</b>	<b>1-800-ALPINE-1 (1-800-257-4631)</b>
<b>NAVIGATION</b>	<b>1-888-NAV-HELP (1-888-628-4357)</b>

Or visit our website at: <http://www.alpine-usa.com>

**ALPINE ELECTRONICS OF AMERICA, INC.,** 19145 Gramercy Place, Torrance, California 90501, U.S.A.

**ALPINE ELECTRONICS OF CANADA, INC.,** 777 Supertest Road, Toronto, Ontario M3J 2M9, Canada

Do not send products to these addresses.

Call the toll free telephone number or visit the website to locate a service center.